

SUPPLEMENTAL ACCESSIBILITY REQUIREMENTS

March 15, 2021

(r2: 2/22/22)

Note: This document is to be applied to new construction and alterations effective 5/1/2021.

TABLE OF CONTENTS

Executive Summary [2](#)

Background [4](#)

How to Use this Document [6](#)

Supplemental Accessibility Requirements [7](#)

Appendix A (Explanatory Material) [79](#)

Appendix B (Additional Accessibility Considerations) [100](#)

Appendix C (Topic by Topic Summary) [106](#)

This publication contains substantial copyrighted material from the 2021 International Building Code, the 2018 International Building Code and ICC A117.1-2017 Standard for Accessible and Usable Buildings and Facilities, International Code Council, Inc., Washington, D.C. Reproduced with permission. All rights reserved.

EXECUTIVE SUMMARY

On the occasion of the 30th anniversary of the Americans with Disabilities Act (ADA), the Port Authority of New York and New Jersey (Port Authority) is proud to introduce its *Port Authority of NY & NJ - Supplemental Accessibility Requirements*, designed to improve the way people with disabilities access our facilities.

This document is the result of a collaboration between the Engineering Department, the Office of Diversity & Inclusion, the Port Authority Abilities Network and expert consultants from the United Spinal Association and Studio 5 Partnership, an architecture firm with extensive accessibility experience. The purpose of the collaboration was to identify ways the Port Authority could go above and beyond the accessibility requirements in existing laws and codes, including the ADA, and implement best practices and new approaches to achieve cutting-edge accessibility in our facilities.

After extensive research, internal discussion and consultation with people with disabilities, the group decided to be early adopters of a modified version of the most up-to-date and progressive accessibility standard in the industry: the 2017 edition of the International Code Council's (ICC) A117.1 Standard for *Accessible and Usable Buildings and Facilities* (ICC A117.1). This new standard, not yet widely adopted, significantly exceeds the existing requirements of the 2018 Edition of the International Building Code (IBC), which incorporates the 2009 edition of ICC A117.1 and aims to be consistent with the 2010 ADA Standards. In addition to adopting much of the latest ICC A117.1, we included several supplemental accessibility provisions of our own, as well as a set of additional accessibility topics to be considered by designers of our facilities (see Appendix B).

A highlight of this document is a set of new space requirements to accommodate the needs of a greater number of people with disabilities, including those who use power wheelchairs and scooters. The larger space requirements will affect numerous areas of design, including restrooms, doorways and turning spaces throughout Port Authority facilities. In addition to the new space criteria, the supplemental requirements enhance accessibility in other ways and for differing groups of users. The disability community has advocated for some of these changes over many years. We expect the example set by the Port Authority to move the accessibility agenda forward, not just locally, but nationally.

Some of the highlights of the supplemental requirements include:

- Larger wheelchair turning space (increased from 60" to 67").

- Longer clear floor space for wheelchairs (increased from 48" to 52").
- Hearing loops at airline gates to assist travelers wearing hearing aids to hear announcements.
- Adult changing stations located in family restrooms in transportation facilities.
- Enhanced requirements for accessible tables in restaurants.

The supplemental requirements will apply to all new Port Authority facilities. When existing facilities are altered, the altered portions will also comply with the supplemental requirements to the extent technically feasible.

By becoming an early adopter of the groundbreaking space requirements and effectuating other changes based on feedback from people with disabilities that have yet to be addressed in any building code or accessibility standard used in the United States, the Port Authority will be a true pioneer. As a result, Port Authority facilities will even better serve the diverse population of people with disabilities who rely on our services.

As we mark the 30th anniversary of the ADA, we are pleased to participate in this exciting effort to move accessibility standards forward.

BACKGROUND

This document was developed using three main sources: the 2017 Edition of the ICC A117.1; proposals to update the 2018 IBC approved by ICC which, once published, will be incorporated in the 2021 IBC; and input from people with disabilities (Port Authority building users and staff) collected over time during by the Office of Diversity and Inclusion and the Engineering Department, Design Division. In particular, valuable input was furnished by the Port Authority Abilities Network – a Port Authority Employee Business Resource Group with a mission to “establish a diverse and inclusive work environment that values, respects and embraces employees for their abilities.”

The 2017 Edition of the ICC A117.1 was preceded by seven editions. The original edition, titled the ANSI A117.1 *Specification for Making Buildings and Facilities Accessible to, and Usable by, the Physically Handicapped*, was published in 1961 in the wake of two world wars. Only 11 pages long, it was the first nationally recognized accessibility standard addressing the built environment and served to guide communities to make the necessary changes for returning veterans. Since its original publication, the standard has grown in size and sophistication, with the 2017 Edition containing an index one page longer than the entire original standard. However, up until 2017, the standard’s requirements for people with mobility disabilities have been based on the “footprint” of the type of manual wheelchair most commonly used in the 1950s and 1960s. That same dated dimensional footprint serves as the basis for most federal accessibility standards, including: The Uniform Federal Accessibility Standards, the Architectural Barriers Act Accessibility Standard, the Americans with Disabilities Act Standards for Accessible Design, and the Fair Housing Accessibility Guidelines.

Under the stewardship of the ICC, accessibility requirements in the ICC A117.1 and the IBC are systematically updated to incorporate new information generated through the code development process. Additionally, they are closely harmonized with accessibility standards and guidelines issued by federal agencies and enforceable under federal civil rights laws. Since its incorporation in 2003, ICC’s efforts have resulted in accessibility requirements that meet, and in a few cases exceed, most federal accessibility requirements. However, none of the standards developers (private-sector or federal) had the tools necessary to ensure their requirements reflected the contemporary needs of the population of wheelchair users, which has changed significantly over time – that is, not until the 2017 edition of the ICC A117.1 was developed.

In 2011, the U.S. Access Board and the U.S. Department of Education funded a study by the Center for Inclusive Design and Environmental Access (IDeA Center) titled *Anthropometry of*

Wheeled Mobility. Like its name suggests, the study provided critical data about the dimensions of various wheeled mobility devices (manual wheelchairs, power wheelchairs, and scooters), the people who use them, and whether existing accessibility standards meet their needs. This study was the first peer-reviewed, credible research about this subject in decades, perhaps ever. Collecting data from 500+ participants and ensuring consistent measurement points and techniques, it was a model for future work to be undertaken internationally. Not surprisingly, the data revealed that user demographics (gender, body size, functional abilities), and diversity of choice in wheeled mobility devices have changed over the last 40 – 50 years. The results of the study afforded standards developers a way to assess existing accessibility requirements to determine their impact i.e., which types of wheeled mobility devices are supported by accessibility standards and which devices (and therefore which users) are not.

With the findings of the study in hand, the members of the ICC A117 Committee spent about five years evaluating how increasing the dimensions in the Standard to accommodate today's population would affect construction. Chapter 3 *Building Blocks* of the Standard includes a set of dimensions that form the basis of the dimensional requirements in the remainder of the Standard. The committee examined the costs and benefits of each potential change. As a result, the 2017 edition includes new expanded requirements that will benefit a far larger percentage of the population than is currently served. For example, in previous editions, a *clear floor space*, the area needed to accommodate an occupied manual wheelchair, was 30 inches wide and 48 inches long. However, the study showed that when the length alone was expanded to 52 inches, it would accommodate 89 percent of users, as compared to 78 percent. Although a change to the width would accommodate even more users, the committee believed it would not yield the same kind of dividend and would have significant impact on construction, such as the elimination of the 3-foot wide door panel found nearly everywhere. In addition, the study revealed that less than 50% of the group of manual and powered wheelchair users could complete a 360° turn in the 60-inch diameter circular *maneuvering space* provided for people to turn around. When that space is increased to 67 inches in diameter, 95 percent of manual wheelchair users are accommodated, as opposed to 80 percent, and maneuverability is improved for both powered wheelchair users and scooter users.

HOW TO USE THIS DOCUMENT

The Supplemental Accessibility Requirements are designed to be a supplement to the 2018 Edition of the International Building Code - with its referenced accessibility standard, the 2009 ICC A117.1. The Requirements include additional accessibility provisions over and above those contained in the 2009 ICC A117.1 and the ADA, many taken from the most recent 2017 ICC A117.1. Large sections excerpted from the 2017 ICC A117.1 or other standards are set out in blue shading. In some sections, material from the 2017 ANSI A117.1 that is unchanged from 2009 is included to provide context for the new 2017 material. Please note that the Requirements are not meant to be a standalone document with all applicable accessibility provisions. Instead, they supplement those contained in the existing versions of the IBC and the ADA. Accordingly, designers should reference the Requirements alongside those other standards. As stated elsewhere, to the extent provisions in the Requirements conflict with existing IBC or ADA provisions, the provision offering the greatest accessibility prevails. Please refer to Appendix A for provision-by-provision explanatory material that details how the Requirements supplement and amend the other accessibility standards. Appendix B lists additional accessibility issues that should be considered by designers, and Appendix C is offered as a convenient topic-by-topic summary.

About the Appendices

- **Appendix A: Explanatory Material**
Provides “plain English” explanations of the provisions in the Supplemental Accessibility Requirements.
- **Appendix B: Additional Accessibility Considerations**
Lists nine additional topics not covered in the Supplemental Accessibility Requirements that should be considered by designers if applicable.
- **Appendix C: Topic by Topic Summary**
Provides a convenient summary table of the Supplemental Accessibility Requirements, organized by topic.

SUPPLEMENTAL ACCESSIBILITY REQUIREMENTS

1.0 Application and Administration

1.1 Purpose. This document contains scoping and technical provisions supplemental to the accessibility requirements of building codes and standards applicable to buildings and facilities subject to the jurisdiction of the Port Authority of New York and New Jersey. These supplemental requirements are to be applied during design, construction, additions to, and alteration of buildings and facilities required to be accessible.

1.2 Conflicts with other accessibility requirements. Where conflicts occur between provisions of this document and other applicable accessibility requirements, the requirements that result in the greatest accessibility shall apply.

1.3 Referenced Standards

1.3.1 ANSI/BHMA. Copies of the referenced standards may be obtained from the Builders Hardware Manufacturers Association, 355 Lexington Avenue, 17th floor, New York, NY 10017 (<http://www.buildershardware.com>).

ANSI/BHMA A156.10 – 2017 Power Operated Pedestrian Doors (Section 3.4).

ANSI/BHMA A156.19 – 2019 American National Standard for Power Assist and Low Energy Power Operated Doors (Section 3.4).

1.3.2 ICC A117. Copies of the referenced standard may be obtained from the International Code Council, 4051 Flossmoor Road, Country Club Hills, IL 60478. (www.iccsafe.org).

ICC A117.1 – 2017 Accessible and Usable Buildings and Facilities (multiple Sections throughout the document).

1.3.3 IEC. Copies of the referenced standard may be obtained from the International Electrotechnical Commission, 3 rue de Varenbe, PO Box 131, 1211 Geneva 20, Switzerland (<https://webstore.iec.ch/home>).

IEC 60118-4: 2014 Electroacoustics – Hearing aids – Part 4: Induction-loop systems for hearing aid purposes - System performance requirements (Section 3.18).

1.3.4 ISO. Copies of the referenced standard may be obtained from the International Organization for Standardization, Chemin de Blandonnet 8, CP

401, 1214 Vernier, Geneva, Switzerland
(<https://www.iso.org/standards.html>).

ISO 7001 – 2007: Graphical symbols – Public information symbols (Section 3.17.2).

- 1.3.5 NYCBC.** Copies of the referenced standard may be obtained from the New York City Buildings Department, 280 Broadway, New York, NY 10007 (<https://www1.nyc.gov/site/buildings/codes/2014-construction-codes.page#bldgs>).
NYCBC 2014: New York City Building Code (Section BC 2410).

2.0 Requirements

2.1 Applicability

- 2.1.1 General.** New construction and alterations and shall comply with 2.1.2 and 2.1.3 as applicable.
- 2.1.2 New construction.** All newly designed and newly constructed areas of buildings and facilities shall comply with these supplemental requirements.
- 2.1.3 Alterations.** When existing buildings and facilities are altered, the altered portions shall comply with these supplemental requirements, unless compliance is technically infeasible. With respect to an alteration of a building or a facility, “technically infeasible” shall mean: something that has little likelihood of being accomplished because existing structural conditions would require removing or altering a load-bearing member that is an essential part of the structural frame; or because other existing physical or site constraints prohibit modification or addition of elements, spaces, or features that are in full and strict compliance with the minimum requirement.

2.2 Space Requirements

- 2.2.1 General.** Turning spaces, clear floor spaces, clearances, wheelchair spaces, and companion seats required by applicable building codes and standards to be accessible shall comply with Section 2.2.

2.2.2 Turning spaces. Where turning spaces are required, they shall comply with Section 304 of the ICC A117.1 (incorporated by reference in Section 1.3.2 and reproduced below).

304.1 General. A turning space shall comply with Section 304.

304.2 Floor surface. Floor surfaces of a turning space shall comply with Section 302. Changes in level shall not be permitted within the turning space.

Exception: Slopes not steeper than 1:48 shall be permitted.

304.3 Size. Turning spaces shall comply with Section 304.3.1 or 304.3.2.

304.3.1 Circular space.

304.3.1.1 New buildings and facilities. In new buildings and facilities, the turning space shall be a circular space with a 67-inch (1700 mm) minimum diameter.

304.3.1.1.1 Overlap. Turning spaces shall be permitted to include knee and toe clearance complying with Section 306. Where the turning space includes knee and toe clearances under an obstruction, the overlap shall comply with all of the following:

1. The depth of the overlap shall not be more than 10 inches (255 mm), and
2. The depth shall not exceed the depth of the knee and toe clearances provided, and
3. The overlap shall be permitted only within the turning circle area shown shaded in Figure 304.3.1.

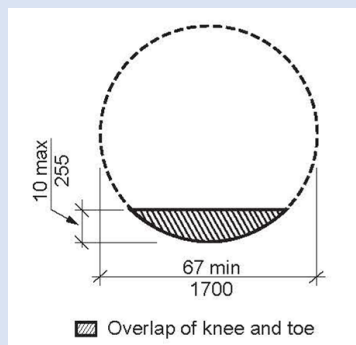

FIGURE 304.3.1.1
CIRCULAR TURNING SPACE - NEW BUILDINGS SIZE AND OVERLAP

304.3.1.2 Existing buildings and facilities. In existing buildings and facilities, the turning space shall be a circular space with a 60-inch (1525 mm) minimum diameter.

304.3.1.2.1 Overlap. Turning spaces shall be permitted to include knee and toe clearance complying with Section 306.

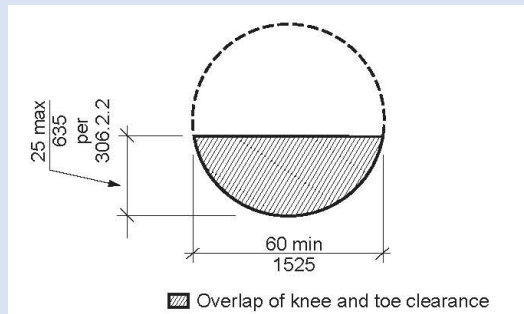

Figure 304.3.1.2

CIRCULAR TURNING SPACE - EXISTING BUILDINGS - SIZE AND OVERLAP

304.3.2 T-shaped space

304.3.2.1 New buildings and facilities. In new buildings and facilities, the turning space shall be a T-shaped space complying with one of the following:

1. A T-shaped space, clear of obstruction, that fits within an area 68 inches (1725 mm) wide and 60 inches (1525 mm) deep, with two arms and one base that are all 36 inches (915 mm) minimum in width. Each arm shall extend 16 inches (405 mm) minimum from each side of the base located opposite the other, and the base shall extend 24 inches (610 mm) minimum from the arms. At the intersection of each arm and the base, the interior corners shall be chamfered for 8 inches (205 mm) minimum along both the arm and along the base.

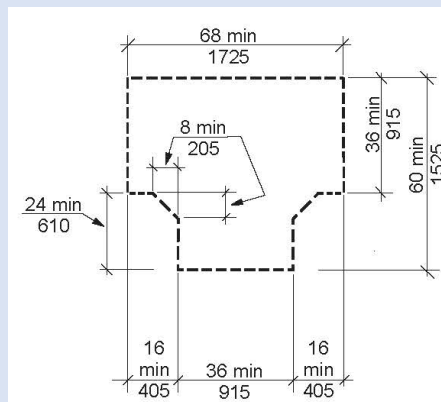

FIGURE 304.3.2.1. (A)

T-SHAPED TURNING SPACE NEW BUILDINGS - OPTION 1

2. A T-shaped space, clear of obstruction, that fits within an area 64 inches (1625 mm) wide and 60 inches (1525 mm) deep, with two arms 38 inches (965 mm) minimum in width and a base 42 inches (1065 mm) minimum in width. Each arm shall extend 11 inches (280 mm) minimum from each side of the base, located opposite the other, and the base shall extend 22 inches (560 mm) minimum from each arm

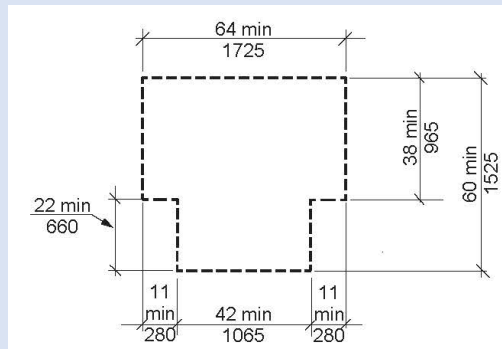

Figure 304.3.2.1(B)
T-SHAPED TURNING SPACE NEW BUILDINGS – OPTION 2

3. A T-shaped space, clear of obstruction, 64 inches (1625 mm) wide and 60 inches (1525 mm) deep, with two arms and one base 40 inches (1015 mm) minimum in width. Each arm shall extend 12 inches (305 mm) minimum from each side of the base and the base shall extend 20 inches (510 mm) minimum from each arm.

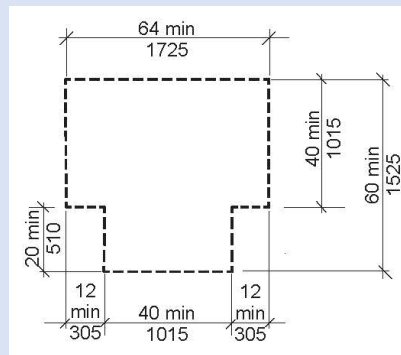
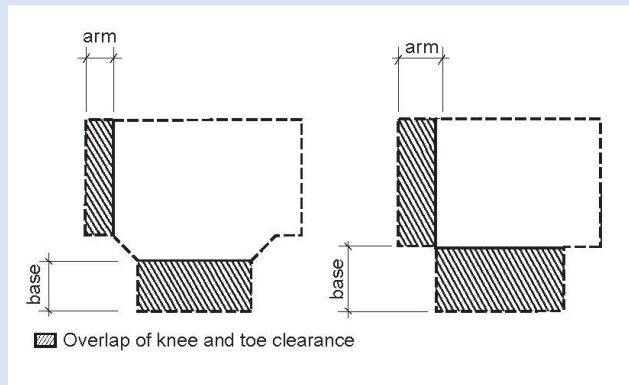

FIGURE 304.3.2.1 (C)
T-SHAPED TURNING SPACE NEW BUILDINGS – OPTION 3

304.3.2.1.1 Overlap. Turning spaces shall be permitted to include knee and toe clearance complying with Section 306 of either the base or one arm. For Option 1, the base or arm is the portion beyond the chamfer.



**FIGURE 304.3.2.1
T-SHAPED TURNING SPACE NEW BUILDINGS – OVERLAP**

304.3.2.2 Existing buildings and facilities. In existing buildings and facilities, the turning space shall be a T-shaped space within a 60-inch (1525 mm) minimum square, with arms and base 36 inches (915 mm) minimum in width. Each arm of the T shall be clear of obstructions 12 inches (305 mm) minimum in each direction, and the base shall be clear of obstructions 24 inches (610 mm) minimum.

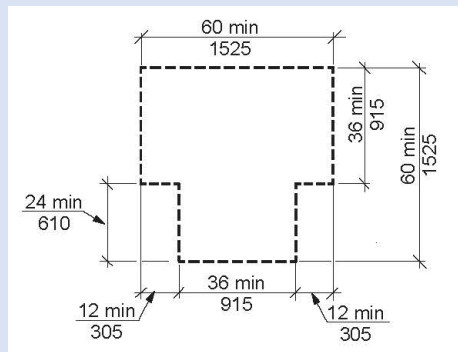

**FIGURE 304.3.2.2
T-SHAPED TURNING SPACE EXISTING BUILDINGS – SIZE AND OVERLAP**

304.3.2.2.1 Overlap. Turning spaces shall be permitted to include knee and toe clearance complying with Section 306 only at the end of either the base or one arm.

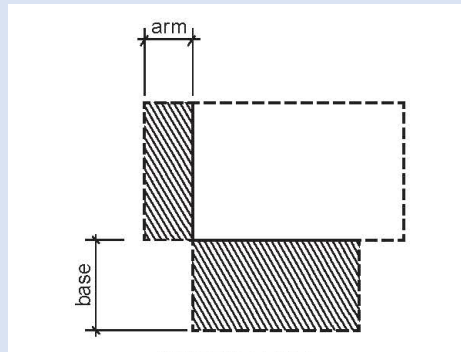

FIGURE 304.3.2.1
T-SHAPED TURNING SPACE – EXISTING BUILDINGS – OVERLAP

304.4 Door swing. Unless otherwise specified, doors shall be permitted to swing into turning spaces.

2.2.3 Clear floor space. Where clear floor spaces are required, they shall comply with Section 305 of ICC A117.1 (incorporated by reference in Section 1.3.2 and reproduced below).

SECTION 305
CLEAR FLOOR SPACE

305.1 General. A clear floor space shall comply with Section 305.

305.2 Floor surfaces. Floor surfaces of a clear floor space shall comply with Section 302. Changes in level shall not be permitted within the clear floor space.

Exception: Slopes not steeper than 1:48 shall be permitted.

305.3 Size.

305.3.1 New buildings and facilities. In new buildings and facilities, the clear floor space shall be 52 inches (1320 mm) minimum in length and 30 inches (760 mm) minimum in width.

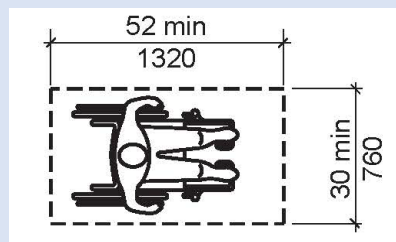
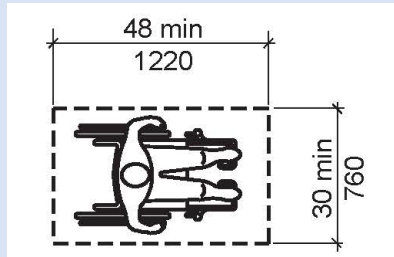

FIGURE 305.3.1
SIZE OF CLEAR FLOOR SPACE – NEW BUILDINGS

305.3.2 Existing buildings and facilities. In existing buildings and facilities, the clear floor space shall be 48 inches (1220 mm) minimum in length and 30 inches (760 mm) minimum in width.



**FIGURE 305.3.2
SIZE OF CLEAR FLOOR SPACE – EXISTING BUILDINGS**

305.4 Knee and toe clearance. Unless otherwise specified, clear floor space shall be permitted to include knee and toe clearance complying with Section 306.

305.5 Position. Unless otherwise specified, clear floor spaces shall be positioned for either forward or parallel approach to an element.

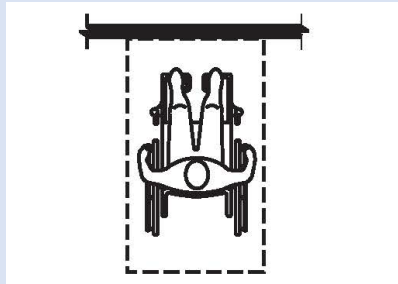

**FIGURE 305.5(A)
POSITION OF CLEAR FLOOR SPACE – FORWARD**

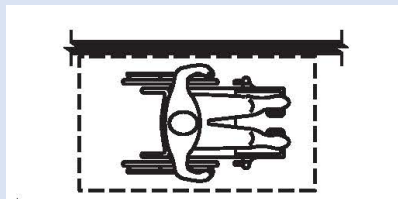

**FIGURE 305.5(B)
POSITION OF CLEAR FLOOR SPACE – PARALLEL**

305.6 Approach. One full, unobstructed side of a clear floor space shall adjoin or overlap an accessible route or adjoin another clear floor space.

305.7 Alcoves. If a clear floor space is in an alcove or otherwise confined on all or part of three sides, additional maneuvering clearances complying with Sections 305.7.1 and 305.7.2 shall be provided, as applicable.

305.7.1 Parallel approach. Where a clear floor space is positioned for a parallel approach, the alcove shall be 60 inches (1525 mm) minimum in width where the depth exceeds 15 inches (380 mm).

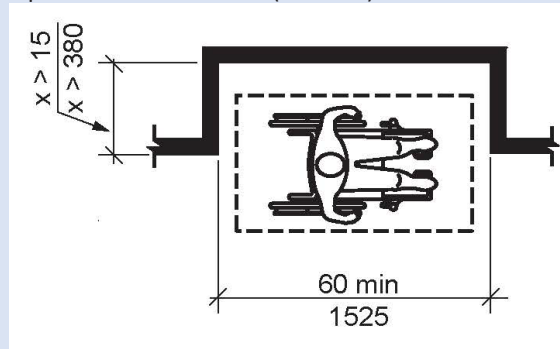

FIGURE 305.7.1
MANEUVERING CLEARANCE IN AN ALCOVE – PARALLEL APPROACH

305.7.2 Forward approach. Where a clear floor space is positioned for a forward approach, the alcove shall be 36 inches (915 mm) minimum in width where the depth exceeds 24 inches (610 mm).

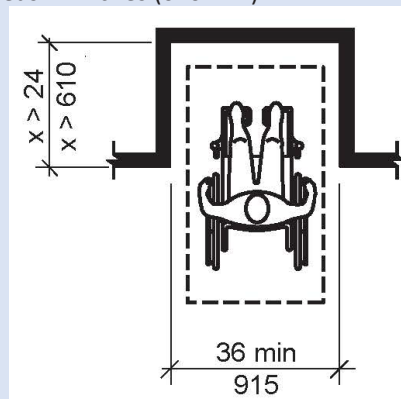

FIGURE 305.7.1
MANEUVERING CLEARANCE IN AN ALCOVE – FORWARD APPROACH

2.2.4 Clearances at transfer-type showers. Where clearances at transfer-type showers are required, they shall comply with Section 608.2.1.2 of the ICC A117.1 (incorporated by reference in Section 1.3.2 and reproduced below).

608.2.1.2 Clearance.

608.2.1.2.1 New buildings and facilities. In new buildings and facilities, a clearance of 52 inches (1320 mm) minimum in length and 36 inches (915 mm) minimum in depth shall be provided adjacent to the open face of the compartment. The length of the clear floor space shall be measured perpendicular from either the control wall or from 4 inches (100 mm) behind the control wall.

608.2.1.2.2 Existing buildings and facilities. In existing buildings and facilities, a clearance of 48 inches (1220 mm) minimum in length measured perpendicular from the control wall, and 36 inches (915 mm) minimum in depth shall be provided adjacent to the open face of the compartment.

2.2.5 Wheelchair spaces in assembly areas. Where wheelchair spaces are required in assembly areas, they shall comply with Sections 802.4 through 802.5.1 of the ICC A117.1 (incorporated by reference in Section 1.3.2 and reproduced below).

802.4.1 New buildings and facilities. In new buildings and facilities, where a wheelchair space is entered from the front or rear, the wheelchair space shall be 52 inches (1320 mm) minimum in depth. Where a wheelchair space is only entered from the side, the wheelchair space shall be 60 inches (1525 mm) minimum in depth.

802.4.2 Existing buildings and facilities. In existing buildings and facilities, where a wheelchair space is entered from the front or rear, the wheelchair space shall be 48 inches (1220 mm) minimum in depth. Where a wheelchair space is only entered from the side, the wheelchair space shall be 60 inches (1525 mm) minimum in depth.

802.5 Approach. Wheelchair spaces shall adjoin an accessible route. The accessible route shall not overlap a wheelchair space.

802.5.1 Overlap. A wheelchair space shall not overlap the required width of an aisle.

Exception: In new buildings, the depth of a wheelchair space shall be permitted to overlap the required aisle width a maximum of 4 inches (100 mm).

2.2.6 Companion seats. Where companion seats are required, they shall be aligned with wheelchair spaces in accordance with Section 802.7.2 of the ICC A117.1 (incorporated by reference in Section 1.3.2 and reproduced below).

802.7.2 Companion seat alignment. In row seating, the companion seat shall be located to provide shoulder alignment with the wheelchair space occupant. The shoulder of the wheelchair space occupant is considered to be 36 inches (915 mm) or more from the front and 12 inches (305 mm) or more from the rear of the wheelchair space. The floor surface for the companion seat shall be at the same elevation as the wheelchair space floor surface.

Exception: Companion seat alignment shall not be required in tiered seating that includes dining surfaces or work surfaces.

2.3 Accessible Routes

2.3.1 General. Accessible routes required by applicable building codes and standards shall comply with Section 2.3.

2.3.2 Clear width. The clear width of an interior accessible route shall be 36 inches (915 mm) minimum. The clear width of an exterior accessible route shall be 48 inches (1220 mm) minimum.

Exceptions: 1. In new buildings and facilities, the clear width shall be permitted to be reduced to 32 inches (815 mm) minimum for a length of 24 inches (610 mm) maximum provided the reduced-width segments are separated by segments that are 52 inches (1320 mm) minimum in length and 36 inches (915 mm) minimum in width.

2. In existing buildings and facilities, the clear width shall be permitted to be reduced to 32 inches (815 mm) minimum for a length of 24 inches (610 mm) maximum provided the reduced width segments are separated by segments that are 48 inches (1220 mm) minimum in length and 36 inches (915 mm) minimum in width.

3. The clear width of an exterior accessible route located within seating areas shall be permitted to be 36 inches (915 mm) minimum.

4. Curb ramps shall be permitted to provide 36 inches (915 mm) minimum clear width.

2.3.3 Clear width at turns. The clear width at turns shall comply with Section 2.3.3.

2.3.3.1 Clear width at 180-degree turns. In new construction, the clear width at 180-degree turns shall comply with Section 403.5.2.1 of the

ICC A117.1 (incorporated by reference in Section 1.3.2 and reproduced below). In existing building and facilities, the clear width at 180-degree turns shall comply with Section 403.5.2.2 of the ICC A117.1 or Option 3 of Section 403.5.2.1 (incorporated by reference in Section 1.3.2 and reproduced below).

403.5.2 Clear width at 180-degree turn.

403.5.2.1 New buildings and facilities. In new building and facilities, where an accessible route makes a 180-degree turn around an object that is equal to or greater than 52 inches (1320 mm) in width, the clear widths in the turn shall comply with Section 403.5.1. Where an accessible route makes a 180-degree turn around an object that is less than 52 inches (1320 mm) inches in width, the clear widths approaching the turn, during the turn and leaving the turn, shall be one of the following sets of dimensions:

1. Approaching width is 36 inches (915 mm) minimum, during width is 60 inches (1525 mm) minimum, and leaving width is 36 inches (915 mm) minimum.
2. Approaching width is 42 (1065 mm) inches minimum, during width is 48 inches (1220 mm) minimum, and leaving width is 42 (1065 mm) inches minimum.
3. Approaching width is 43 inches (1090 mm) minimum, during width is 43 inches (1090 mm) minimum, and leaving width is 43 inches (1090 mm) minimum.

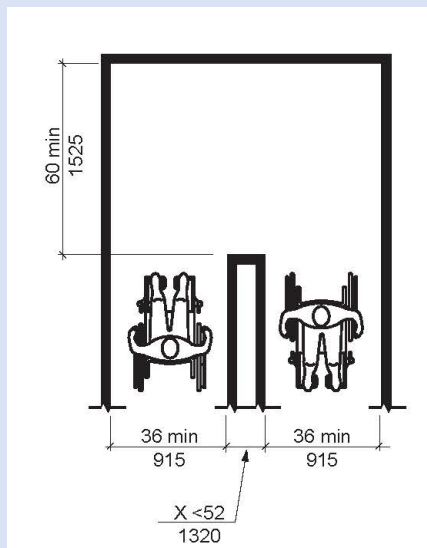

FIGURE 403.5.2.1(A)

CLEAR WIDTH AT 180-DEGREE TURN – NEW BUILDINGS – OPTION 1

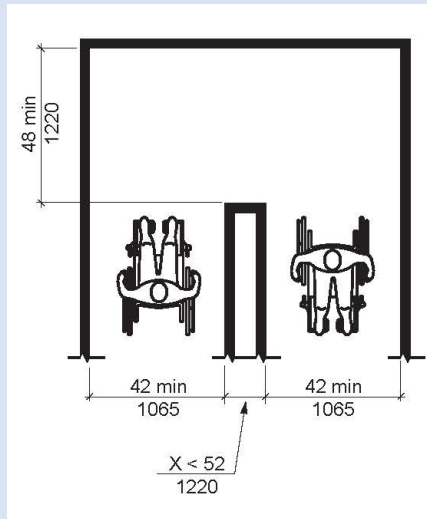

FIGURE 403.5.2.1(B)
CLEAR WIDTH AT 180-DEGREE TURN – NEW BUILDINGS – OPTION 2

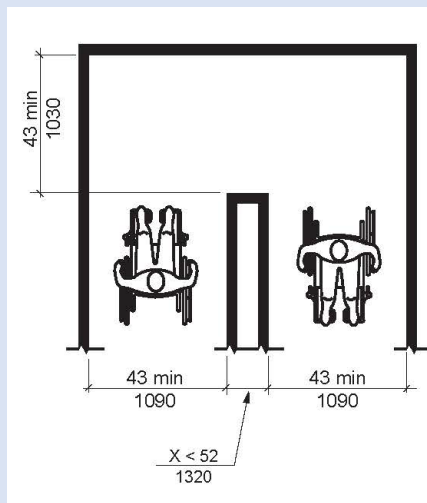

FIGURE 403.5.2.1(C)
CLEAR WIDTH AT 180-DEGREE TURN – NEW BUILDINGS – OPTION 3

403.5.2.2 Existing buildings and facilities. In existing buildings and facilities, where an accessible route makes a 180 degree turn around an object that is less than 48 inches (1220 mm) in width, clear widths shall be 42 inches (1065 mm) minimum approaching the turn, 48 inches (1220 mm) minimum during the turn, and 42 inches (1065 mm) minimum leaving the turn.

Exception: This section shall not apply where the clear width during the turn is 60 inches (1525 mm) minimum.

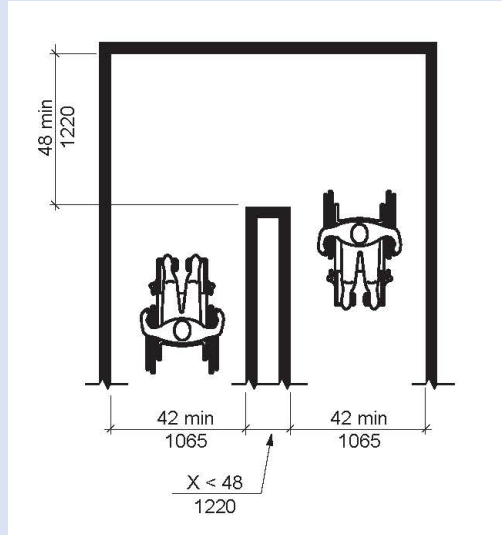

FIGURE 403.5.2.2(A)
CLEAR WIDTH AT 180-DEGREE TURN - EXISTING BUILDINGS

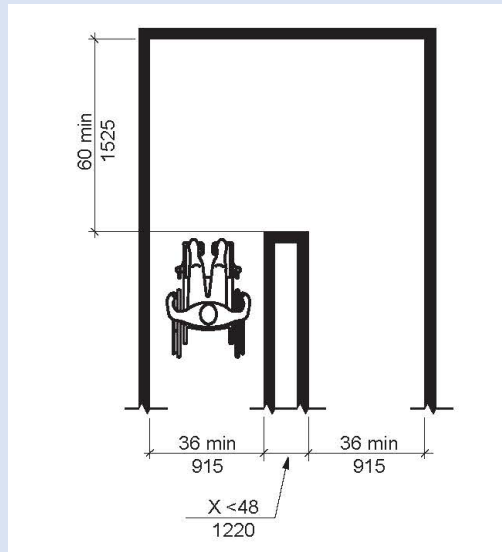

FIGURE 403.5.2.2(B)
CLEAR WIDTH AT 180-DEGREE TURN - EXISTING BUILDINGS – EXCEPTION

- 2.3.3.2 Clear width at 90-degree turns.** In new construction, the clear width at 90-degree turns shall comply with Section 403.5.3.1 of the ICC A117.1 (incorporated by reference in Section 1.3.2 and reproduced below). In existing building and facilities, the clear width at 90-degree turns shall comply with Section 403.5.3.2 of the ICC A117.1 (incorporated by reference in Section 1.3.2 and reproduced below).

403.5.3 Clear width at 90-degree turn.

403.5.3.1 New buildings and facilities. In new buildings and facilities, where an accessible route makes a 90-degree turn the clear widths approaching the turn and leaving the turn shall be one of the following sets of dimensions:

1. Both legs of the turn shall be 40 inches (1015 mm) minimum in width. The width of each leg of the turn shall be maintained for 28 inches (710 mm) minimum from the inner corner.
2. Where the interior corners of the turn are chamfered for 8 inches minimum (205 mm) along both walls, both legs of the turn shall be 36 inches (915 mm) minimum in width.
3. Where one leg of the turn is 42 inches (1065 mm) minimum in width, the other shall be permitted to be 38 inches (965 mm) minimum in width.
4. Where one leg of the turn is 44 inches (1120 mm) minimum in width, the other shall be permitted to be 36 inches (915 mm) minimum in width.

Exceptions:

1. Where an accessible route makes a 90-degree turn at doors, doorways and gates complying with Section 404.2.3, the route shall not be required to comply with this section.
2. Where an accessible route makes a 90-degree turn at an elevator or platforms lifts complying with Sections 407 through 410, the accessible route shall not be required to comply with this section.

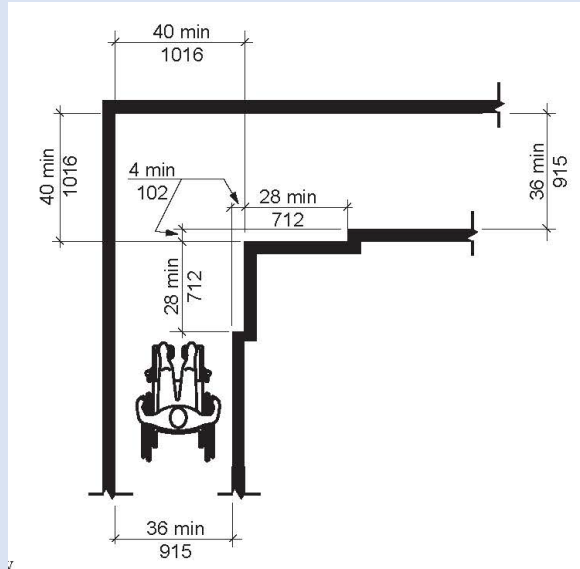

FIGURE 403.5.3.1(A)

CLEAR WIDTH AT 90-DEGREE TURN – NEW BUILDINGS – OPTION 1

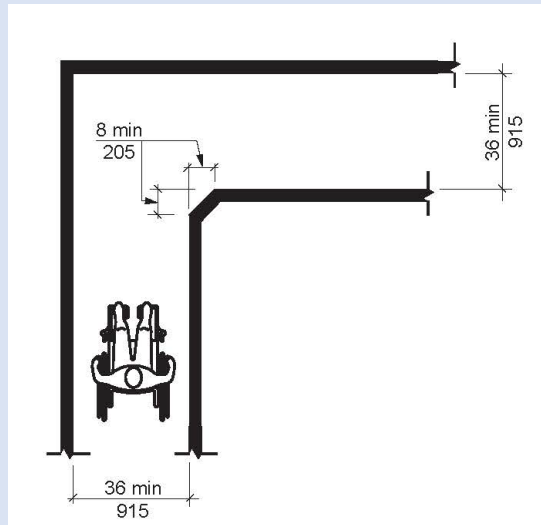

FIGURE 403.5.3.1(B)

CLEAR WIDTH AT 90-DEGREE TURN – NEW BUILDINGS – OPTION 2

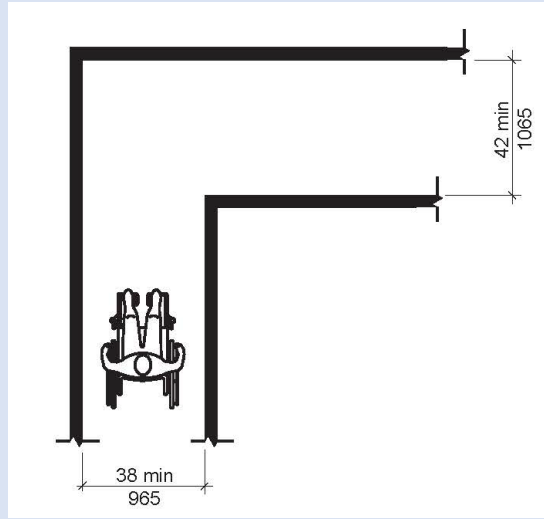

FIGURE 403.5.3.1(C)
CLEAR WIDTH AT 90-DEGREE TURN – NEW BUILDINGS – OPTION 3

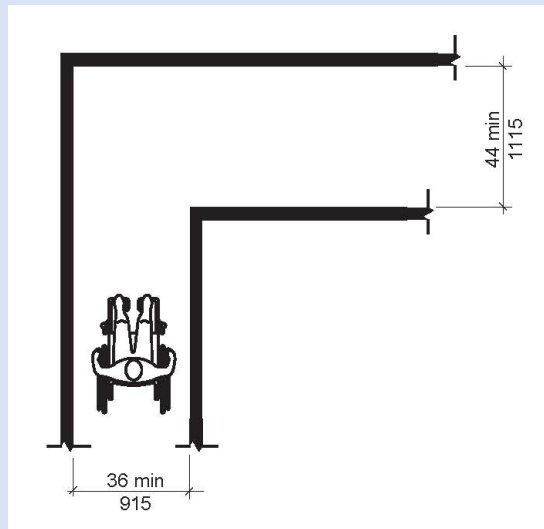
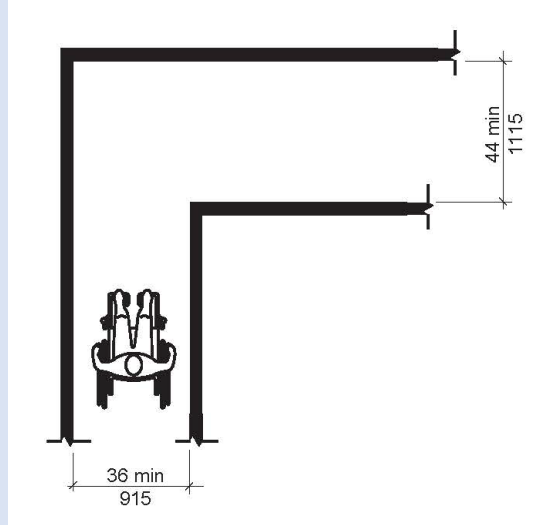

FIGURE 403.5.3.1(D)
CLEAR WIDTH AT 90-DEGREE TURN – NEW BUILDINGS – OPTION 4

403.5.3.2 Existing buildings and facilities. In existing buildings and facilities, where an accessible route makes a 90-degree turn the clear widths approaching the turn and leaving the turn shall be 36 inches (915 mm) minimum.



**FIGURE 403.5.3.2
CLEAR WIDTH AT 90-DEGREE TURN – EXISTING BUILDINGS**

2.3.4 Passing Space. In new construction, passing space shall comply with Section 403.5.4.1 of the ICC A117.1 (incorporated by reference in Section 1.3.2 and reproduced below). In existing building and facilities, passing space shall be sized in accordance with Section 403.5.4.2 of the ICC A117.1 (incorporated by reference in Section 1.3.2 and reproduced below).

403.5.4.1 New buildings and facilities. In new buildings and facilities, an accessible route with a clear width less than 60 inches (1525 mm) shall provide passing spaces at intervals of 200 feet (61 m) maximum. Passing spaces shall be either a 60-inch (1525 mm) minimum by 60-inch (1525 mm) minimum space, or an intersection of two walking surfaces that provide a T-shaped turning space complying with Section 304.3.2.1, provided the base and arms of the T-shaped space extend 52 inches (1320 mm) minimum beyond the intersection.

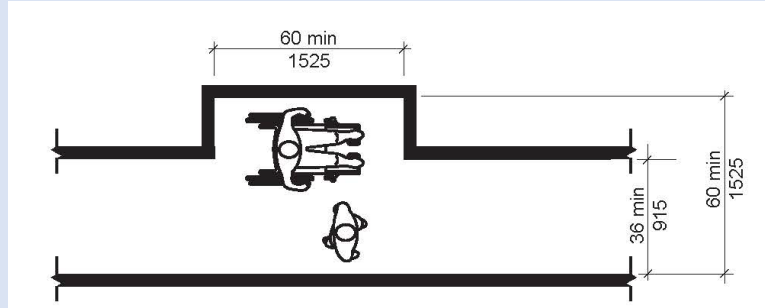

**FIGURE 403.5.4.1(A)
PASSING SPACE – NEW BUILDINGS – 60 X 60 OPTION**

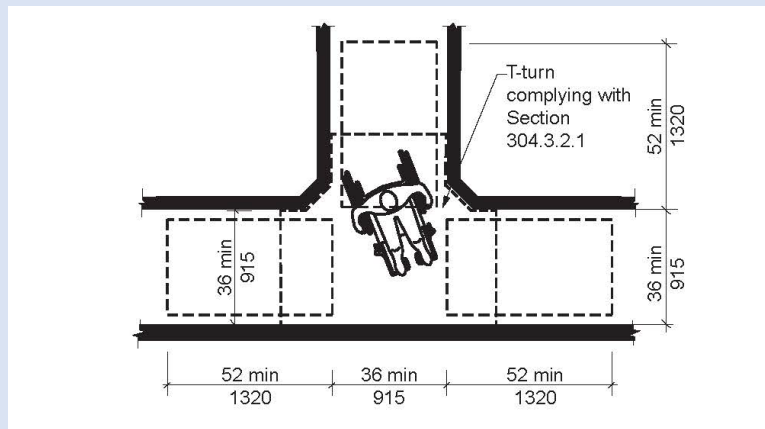

**FIGURE 403.5.4.1(B)
PASSING SPACE – NEW BUILDINGS – T-TURN OPTION**

403.5.4.2 Existing buildings and facilities. In existing buildings and facilities, an accessible route with a clear width less than 60 inches (1525 mm) shall provide passing spaces at intervals of 200 feet (61 m) maximum. Passing spaces shall be either a 60-inch (1525 mm) minimum by 60-inch (1525 mm) minimum space, or an intersection of two walking surfaces that provide a T-shaped turning space complying with Section 304.3.2, provided the base and arms of the T-shaped space extend 48 inches (1220 mm) minimum beyond the intersection.

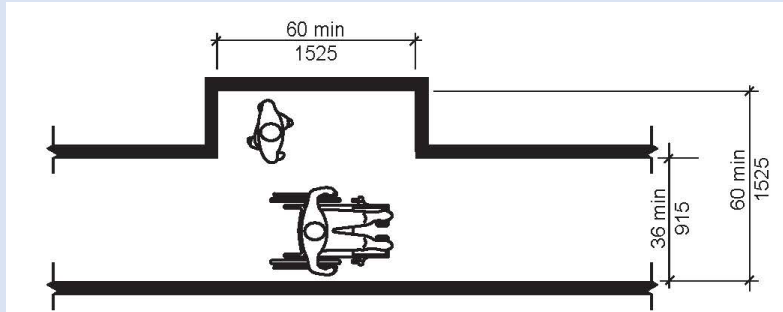

FIGURE 403.5.4.2(A)
PASSING SPACE – EXISTING BUILDINGS – 60 X 60 OPTION

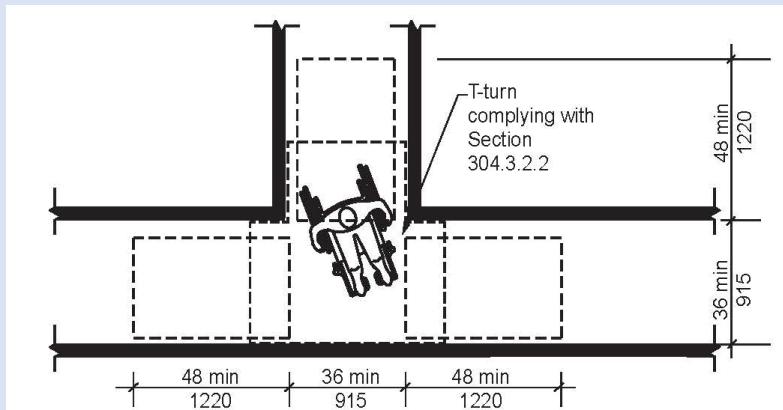

FIGURE 403.5.4.2(B)
PASSING SPACE – EXISTING BUILDINGS – T-TURN OPTION

2.4 Ramps

2.4.1 General. Ramps required by applicable building codes and standards to be accessible shall comply with Section 2.4.

2.4.2 Change in direction at landings. Ramps that change direction between runs at landings shall have a clear landing 60 inches (1525 mm) minimum by 60 inches (1525 mm) minimum.

2.5 Exception for Operable Parts of Emergency Aid Devices.

2.5.1 General. Where applicable building codes and standards require operable parts to be accessible, emergency aid devices, such as fire department hose connections, valve controls, gauges, police call boxes and annunciator panels shall not be required to be accessible, provided that they are used only for emergencies by emergency personnel acting in their official capacity.

2.6 Doors, Doorways and Gates.

2.6.1 General. Doors, doorways and gates required to be accessible by applicable building codes and standards shall comply with Section 2.6.

2.6.2 Automatic doors required. At least one door at each exterior entrance required to be accessible shall have a full power-operated door or low-energy power-operated door where such entrances serve the occupancies and occupant loads specified in Table 2.6.2. In mixed occupancy buildings where the occupancies listed in Table 2.6.2 have an aggregate occupant load greater than 300, all shared exterior entrances serving those occupancies shall comply with this section. Where entrances required to provide automatic doors include two doors in series, both doors in the series shall be full power-operated or low-energy power-operated doors.

Exception: In alterations where doors and door frames are not removed and replaced, altered entrances shall not be required to provide automatic or power-assist doors.

**Table 2.6.2
PUBLIC ENTRANCES WITH POWER-OPERATED DOORS**

OCCUPANCY	OCCUPANT LOAD GREATER THAN
A-1, A-2, A-3, A-4	300
B, M, R-1	500

2.6.3 Technical requirements. Doors, doorways, and gates for user passage shall comply with Section 404 of the ICC A117.1 (incorporated by reference in Section 1.3.2 and reproduced below).

**SECTION 404
DOORS, DOORWAYS AND GATES**

404.1 General. Doors, doorways and gates that are part of an accessible route shall comply with Section 404.
Exception: Doors, doorways and gates designed to be operated only by security personnel shall not be required to comply with Sections 404.2.3, 404.2.6, 404.2.7, 404.2.8, 404.3.1, 404.3.2, 404.3.4, 404.3.7 and 404.3.8.

404.2 Manual doors, doorways and manual gates. Manual doors, doorways and manual gates intended for user passage shall comply with Section 404.2.

404.2.1 Double-leaf doors and gates. At least one of the active leaves of doorways with two leaves shall comply with Sections 404.2.2 and 404.2.3.

404.2.2 Clear width. Doorways shall have a clear opening width of 32 inches (815 mm) minimum. Clear opening width of doorways with swinging doors shall be measured between the face of door and stop, with the door open 90 degrees. Openings more than 24 inches (610 mm) in depth at doors and doorways without doors shall provide a clear opening width of 36 inches (915 mm) minimum. There shall be no projections into the clear opening width lower than 34 inches (865 mm) above the floor. Projections into the clear opening width between 34 inches (865 mm) and 80 inches (2030 mm) above the floor shall not exceed 4 inches (100 mm).

Exceptions:

1. Door closers and door stops shall be permitted to be 78 inches (1980 mm) minimum above the floor.
2. In alterations, a projection of 5/8 inch (16 mm) maximum into the required clear opening width shall be permitted for the latch side stop.

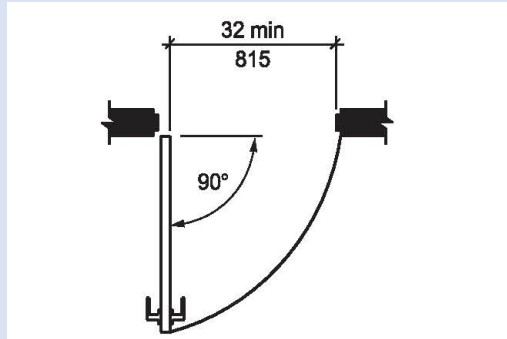

**FIGURE 404.2.2(A)
CLEAR WIDTH OF DOORWAYS – HINGED DOOR**

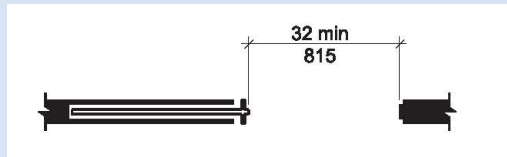

**FIGURE 404.2.2(B)
CLEAR WIDTH OF DOORWAYS – SLIDING DOOR**

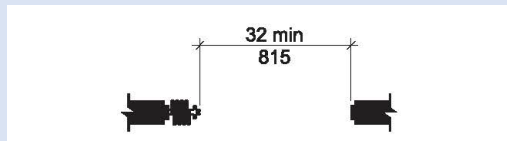

**FIGURE 404.2.2(C)
CLEAR WIDTH OF DOORWAYS – FOLDING DOOR**

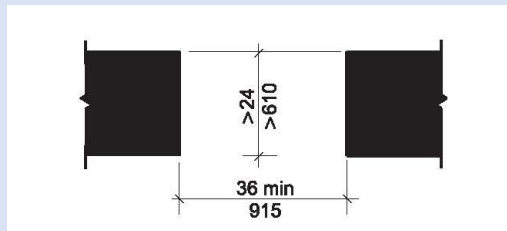

**FIGURE 404.2.2(D)
CLEAR WIDTH OF DOORWAYS – DOORWAYS WITHIN DOOR**

404.2.3 Maneuvering clearances. Minimum maneuvering clearances at doors and gates shall comply with Section 404.2.3. Maneuvering clearances shall include the full clear opening width of the doorway and the required latch-side or hinge-side clearance.

404.2.3.1 Floor surface. The floor surface within the maneuvering clearances shall have a slope not steeper than 1:48 and shall comply with Section 302.

404.2.3.2 Swinging doors and gates. The floor surface within the maneuvering clearances shall have a slope not steeper than 1:48 and shall comply with Section 302. Swinging doors and gates shall have maneuvering clearances complying with Table 404.2.3.2.

TABLE 404.2.3.2 – MANEUVERING CLEARANCES AT MANUAL SWINGING DOORS AND GATES

TYPE OF USE		MANEUVERING CLEARANCES AT MANUAL SWINGING DOOR	
Approach Direction	Door or Gate Side	Perpendicular to Doorway	Parallel to Doorway (beyond latch unless noted)
From front	Pull	60 inches (1525 mm)	18 inches (455 mm)
From front	Push	52 inches (1320 mm) ⁴	0 inches (0 mm)
From hinge side	Pull	60 inches (1525 mm)	36 inches (915 mm)
From hinge side	Pull	54 inches (1370 mm)	42 inches (1065 mm)
From hinge side	Push	42 inches (1065 mm) ¹	22 inches (560 mm) ³
From latch side	Pull	48 inches (1220 mm) ²	24 inches (610 mm)
From latch side	Push	42 inches (1065 mm) ²	24 inches (610 mm)

¹ Add 6 inches (150 mm) if closer and latch provided.

² Add 6 inches (150 mm) if closer provided.

³ Beyond hinge side

⁴ In existing buildings and facilities, the dimension perpendicular to the door or gate for the front direction on the push side shall be 48 inches (1220 mm).

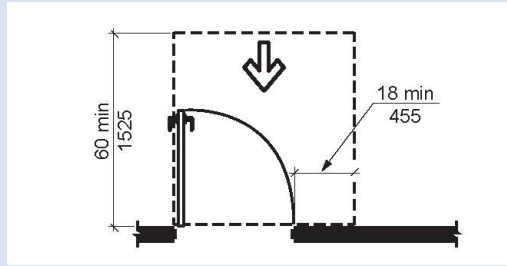

FIGURE 404.2.3.2(A)
MANEUVERING CLEARANCE AT MANUAL SWINGING DOORS
FRONT APPROACH – PULL SIDE

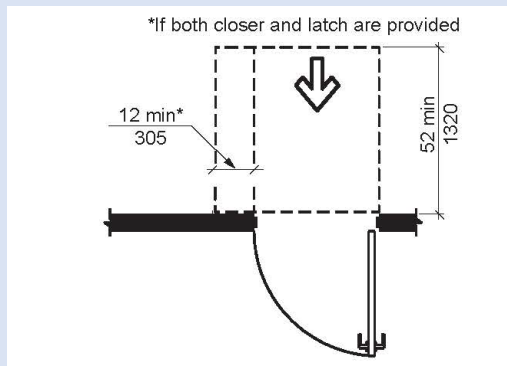

FIGURE 404.2.3.2(B)
MANEUVERING CLEARANCE AT MANUAL SWINGING DOORS
FRONT APPROACH – PUSH SIDE – NEW BUILDINGS

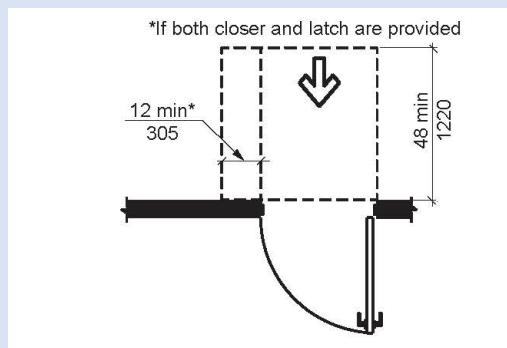

FIGURE 404.2.3.2(C)
MANEUVERING CLEARANCE AT MANUAL SWINGING DOORS
FRONT APPROACH – PUSH SIDE – EXISTING BUILDINGS FOOTNOTE 4

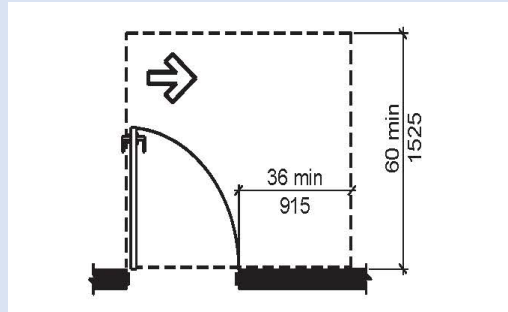

FIGURE 404.2.3.2(D)
MANEUVERING CLEARANCE AT MANUAL SWINGING DOORS
HINGE APPROACH – PULL SIDE

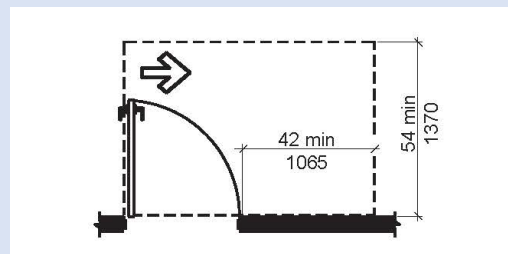

FIGURE 404.2.3.2(E)
MANEUVERING CLEARANCE AT MANUAL SWINGING DOORS
HINGE APPROACH – PULL SIDE

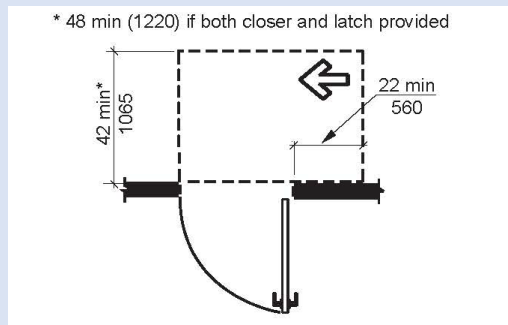

FIGURE 404.2.3.2(F)
MANEUVERING CLEARANCE AT MANUAL SWINGING DOORS
HINGE APPROACH – PUSH SIDE

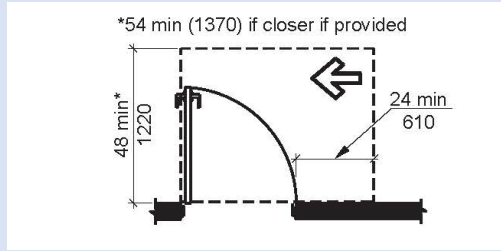

FIGURE 404.2.3.2(G)
MANEUVERING CLEARANCE AT MANUAL SWINGING DOORS
LATCH APPROACH – PULL SIDE

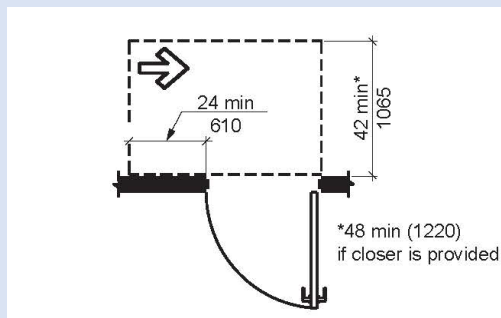

FIGURE 404.2.3.2(H)
MANEUVERING CLEARANCE AT MANUAL SWINGING DOORS
LATCH APPROACH – PUSH SIDE

404.2.3.3 Sliding and folding doors. Sliding doors and folding doors shall have maneuvering clearances complying with Table 404.2.3.3.

TABLE 404.2.3.3 – MANEUVERING CLEARANCES AT SLIDING AND FOLDING DOORS

Approach Direction	MINIMUM MANEUVERING CLEARANCES	
	Perpendicular to Doorway	Parallel to Doorway (beyond latch unless noted)
From front	52 inches (1320 mm) ²	0 inches (0 mm)
From non-latch side	42 inches (1065 mm)	22 inches (60 mm) ¹
From latch side	42 inches (1065 mm)	24 inches (610 mm)

¹ Add 6 inches (150 mm) if closer and latch provided.

² In existing buildings and facilities, the dimension perpendicular to the door for the front direction shall be 48 inches (1220 mm) minimum.

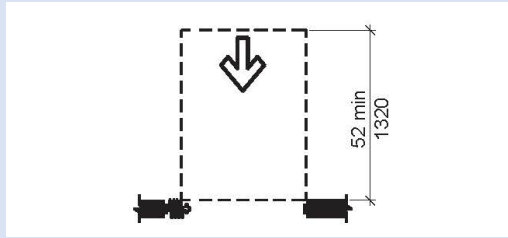

FIGURE 404.2.3.3(A)
MANEUVERING CLEARANCE AT SLIDING AND FOLDING DOORS
FRONT APPROACH – NEW BUILDINGS

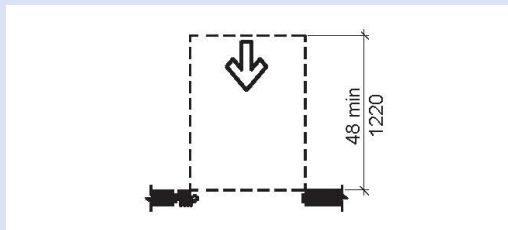

FIGURE 404.2.3.3(B)
MANEUVERING CLEARANCE AT SLIDING AND FOLDING DOORS
FRONT APPROACH – EXISTING BUILDINGS
FOOTNOTE 2

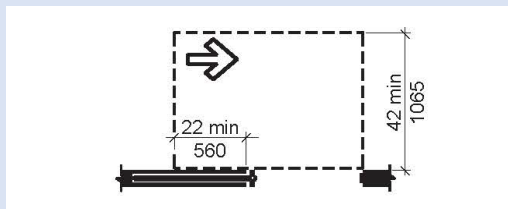

FIGURE 404.2.3.3(C)
MANEUVERING CLEARANCE AT SLIDING AND FOLDING DOORS
FRONT APPROACH – POCKET OR HINGE APPROACH

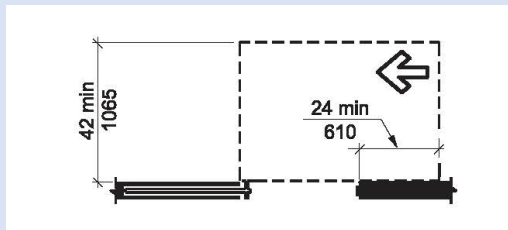

FIGURE 404.2.3.3(D)
MANEUVERING CLEARANCE AT SLIDING AND FOLDING DOORS
FRONT APPROACH – STOP OR LATCH APPROACH

404.2.3.4 Doorways without doors or gates. Doorways without doors or gates that are less than 36 inches (915 mm) in width shall have maneuvering clearances complying with Table 404.2.3.4.

TABLE 404.2.3.4—MANEUVERING CLEARANCES FOR DOORWAYS WITHOUT DOORS OR GATES

Approach Directions	MINIMUM MANEUVERING CLEARANCES Perpendicular to Doorway
From front	52 inches (1320 mm) ¹
From side	42 inches (1065 mm)

¹ In existing buildings and facilities the dimension perpendicular to the doorway for the front direction shall be 48 inches (1220 mm) minimum.

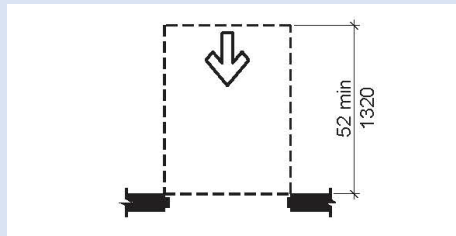

**FIGURE 404.2.3.4(A)
MANEUVERING CLEARANCES FOR DOORWAYS WITHOUT DOORS OR GATES –
FRONT APPROACH – NEW BUILDINGS**

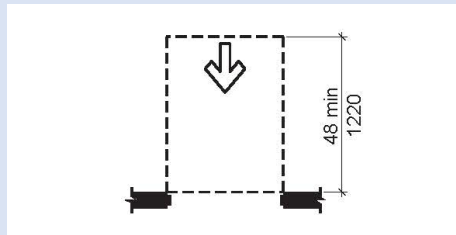

**FIGURE 404.2.3.4(B)
MANEUVERING CLEARANCES FOR DOORWAYS WITHOUT DOORS OR GATES –
FRONT APPROACH – EXISTING BUILDINGS – FOOTNOTE 1**

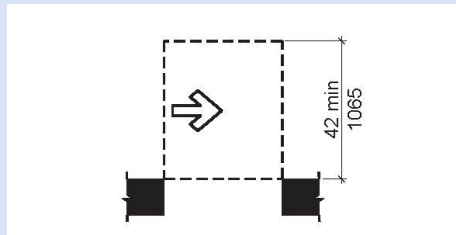

**FIGURE 404.2.3.4(C)
MANEUVERING CLEARANCES FOR DOORWAYS WITHOUT DOORS OR GATES –
SIDE APPROACH**

404.2.3.5 Recessed doors and gates. Where any obstruction within 18 inches (455 mm) of the latch side of a doorway projects more than 8 inches (205 mm) beyond the face of the door or gate, measured perpendicular to the face of the door or gate, maneuvering clearances for a forward approach shall be provided.

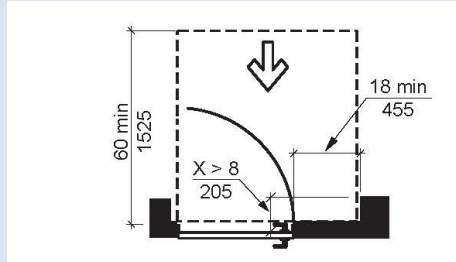

FIGURE 404.2.3.5(A)
RECESSED DOORS AND GATES – NEW BUILDINGS – PULL SIDE

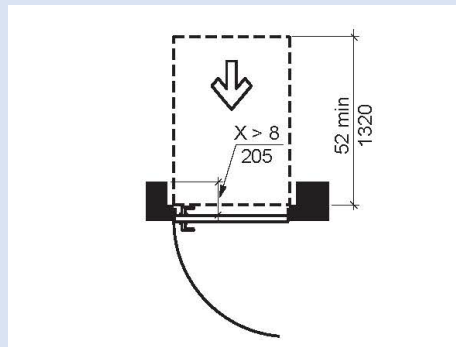

FIGURE 404.2.3.5(B)
RECESSED DOORS AND GATES – NEW BUILDINGS – PUSH SIDE

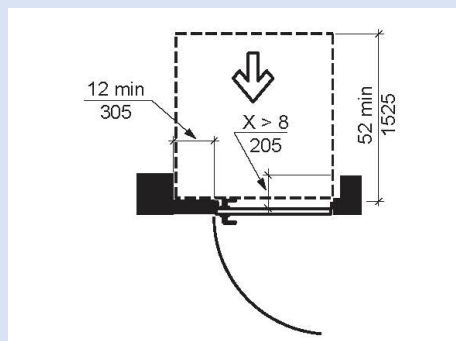

FIGURE 404.2.3.5(C)
**RECESSED DOORS AND GATES – NEW BUILDINGS – PUSH SIDE –
 DOOR PROVIDED WITH BOTH CLOSER AND LATCH**

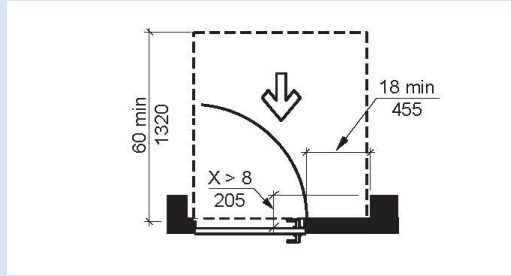

FIGURE 404.2.3.5(D)
RECESSED DOORS AND GATES – EXISTING BUILDINGS – PULL SIDE

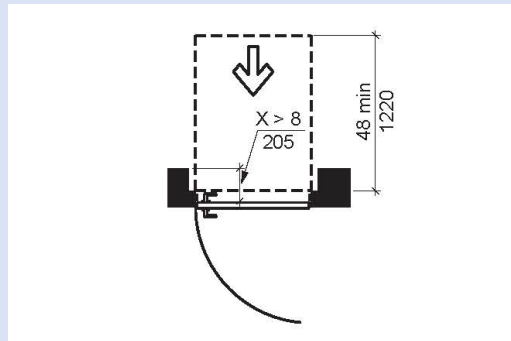

FIGURE 404.2.3.5(E)
RECESSED DOORS AND GATES – EXISTING BUILDINGS – PUSH SIDE

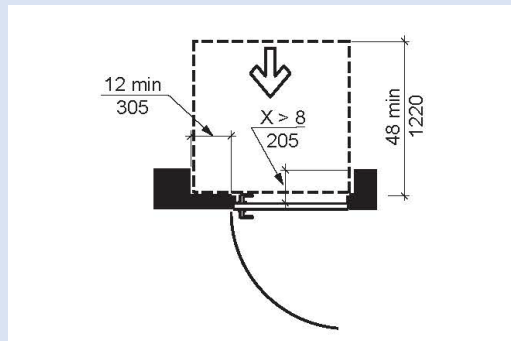

FIGURE 404.2.3.5(F)
**RECESSED DOORS AND GATES – EXISTING BUILDINGS
PUSH SIDE – DOOR PROVIDED WITH BOTH CLOSER AND LATCH**

404.2.4 Thresholds. If provided, thresholds at doorways shall be ½ inch (13 mm) maximum in height. Raised thresholds and changes in level at doorways shall comply with Sections 302 and 303.

Exception: An existing or altered threshold shall be permitted to be ¾ inch (19 mm) maximum in height provided that the threshold has a beveled edge on each side with a maximum slope of 1:2 for the height exceeding ¼ inch (6.4 mm).

404.2.5 Two doors or gates in series. Distance between two hinged or pivoted doors or gates in series shall be 48 inches (1220 mm) minimum plus the width of any door or gate swinging into the space. The space between the doors and gates shall provide a turning space.

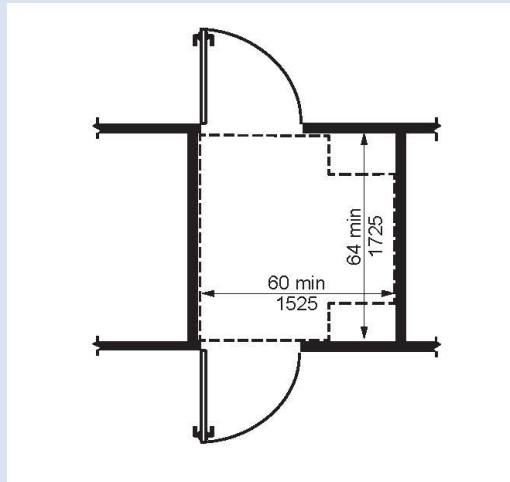

FIGURE 404.2.5(A)
TWO DOORS OR GATES IN A SERIES – NEW BUILDINGS

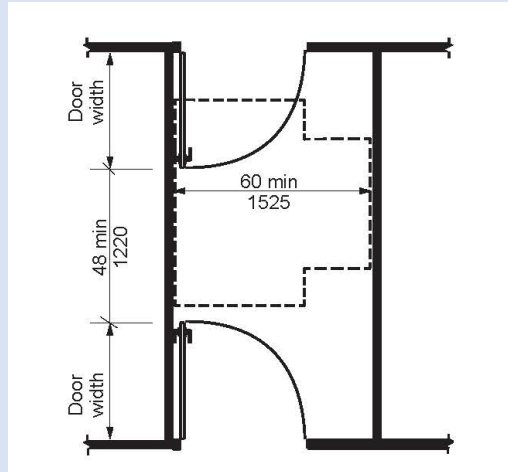

FIGURE 404.2.5(B)
TWO DOORS OR GATES IN A SERIES – NEW BUILDINGS

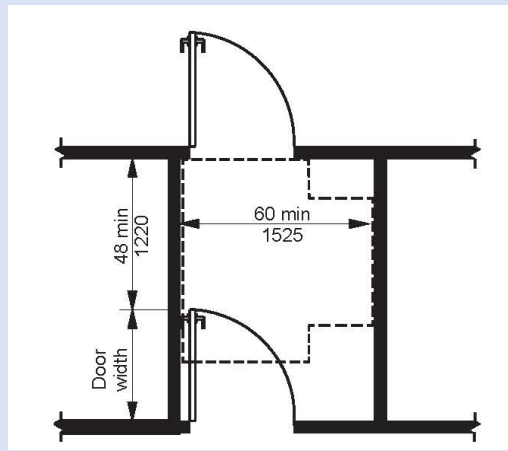

FIGURE 404.2.5(C)
TWO DOORS OR GATES IN A SERIES – NEW BUILDINGS

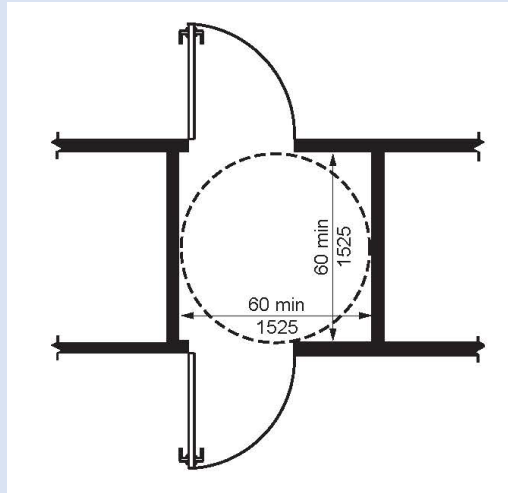

FIGURE 404.2.5(D)
TWO DOORS OR GATES IN A SERIES – EXISTING BUILDINGS

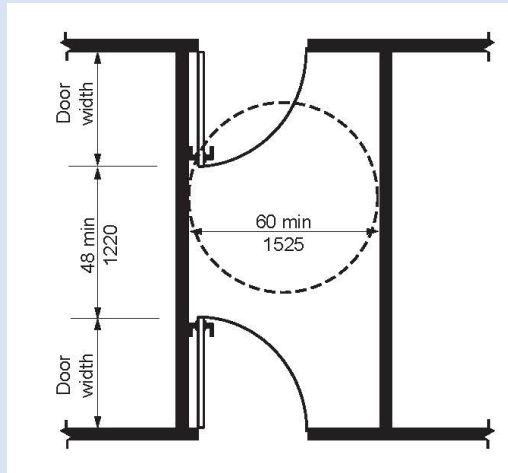

FIGURE 404.2.5(E)
TWO DOORS OR GATES IN A SERIES – EXISTING BUILDINGS

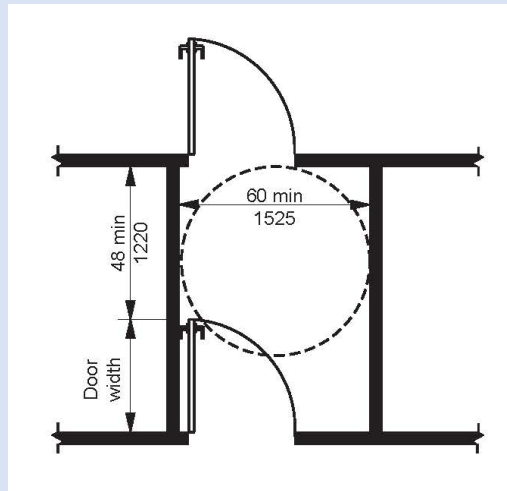

FIGURE 404.2.5(F)
TWO DOORS OR GATES IN A SERIES – EXISTING BUILDINGS

404.2.6 Door and gate hardware. Handles, pulls, latches, locks and other operable parts on doors and gates shall have a shape that is easy to grasp with one hand and does not require tight grasping, pinching or twisting of the wrist to operate. The operational force to retract latches or disengage devices that hold the door or gate in a closed position shall be as follows:

1. Hardware operation by a forward, pushing or pulling motion: 15 pounds (66.7 N) maximum.
2. Hardware operation by a rotational motion: 28 inch-pounds (315 N-cm) maximum.

404.2.6.1 Hardware height. Operable parts of such hardware shall be 34 inches (865 mm) minimum and 48 inches (1220 mm) maximum above the floor. Where sliding doors are in the fully open position, operating hardware shall be exposed and usable from both sides.

404.2.7 Closing speed. Door and gate closing speed shall comply with 404.2.7.

404.2.7.1 Door and gate closers. Door and gate closers shall be adjusted so that from an open position of 90 degrees, the time required to move the door or gate to an open position of 12 degrees shall be 5 seconds minimum.

404.2.7.2 Spring hinges. Door and gate spring hinges shall be adjusted so that from an open position of 70 degrees, the door or gate shall move to the closed position in 1.5 seconds minimum.

404.2.8 Door and gate opening force. Fire doors and doors or gates required to be equipped with panic hardware, break away features or other factors requiring higher opening force for safety reasons shall have the minimum opening force allowable in scoping provisions adopted by the appropriate administrative authority. For other doors or gates, the force for pushing or pulling open doors or gates shall be as follows:

1. Interior hinged door: 5.0 pounds (22.2 N) maximum.
2. Sliding or folding door: 5.0 pounds (22.2 N) maximum.

Exception:

The force required to retract latch bolts or disengage other devices that hold the door or gate in a closed position shall not apply to panic hardware, delayed egress devices or fire-rated hardware.

404.2.9 Door and gate surface. Door and gate surfaces within 10 inches (255 mm) of the floor, measured vertically, shall be smooth surfaces on the push side extending the full width of the door or gate. Door and gate hardware or any other obstruction or protrusion shall not be mounted in nor extend into the area within 10 inches (255 mm) of the floor. Parts creating horizontal or vertical joints in such surfaces shall be within 1/16 inch (1.6 mm) of the same plane as the other. Cavities created by added kick plates shall be capped.

Exception:

1. Sliding doors shall not be required to comply with this section.
2. Tempered glass doors without stiles and having a bottom rail or shoe with the top leading edge tapered at no less than 60 degrees from the horizontal shall not be required to comply with the 10-inch (255 mm) bottom rail height requirement.
3. Doors and gates that do not extend to within 10 inches (255 mm) of the floor shall not be required to comply with this section.
4. The installation of kick plates on existing doors and gates without a smooth surface within 10 inches (255 mm) of the floor shall be permitted. The kick plates shall extend to 10 inches (255 mm) above the floor and no more than 1 inch (25 mm) from the sides and bottom of the door. Cavities created by such kickplates shall be capped.

404.2.10 Vision lites. doors, gates and sidelites adjacent to doors or gates containing one or more glazing panels that permit viewing through the panels shall have the bottom of at least one panel on either the door, gate or an adjacent sidelite 43 inches (1090 mm) maximum above the floor.

Exception: Vision lites with the lowest part more than 66 inches (1675 mm) above the floor shall not be required to comply with this section.

404.3 Automatic and power-assisted doors and gates. Automatic doors and gates shall comply with Section 404.3. Full powered automatic doors and gates shall comply with ANSI/BHMA A156.10 listed in Section 106.2.7. Power-assist doors and gates and low-energy automatic doors and gates shall comply with ANSI/BHMA A156.19 listed in Section 106.2.6.

404.3.1 Public entrances. Where an automatic door or gate is required at a building or facility public entrance, it shall be a full powered automatic or a low-energy automatic door or gate.

404.3.2 Vestibules. Where an entrance includes a vestibule, at least one exterior door or gate and one interior door or gate in the vestibule shall have the same type of automatic door or gate opener.

404.3.3 Clear width. Doorways shall have a clear opening width of 32 inches (815 mm) in power-on and power-off mode. The minimum clear opening width for automatic door systems shall be based on the clear opening width provided with all leaves in the open position.

404.3.4 Maneuvering clearances. Maneuvering clearances at power-assisted doors and gates shall comply with Section 404.2.3. Maneuvering clearances complying with Section 404.2.3 shall be provided on the egress side of low-energy automatic and full power automatic doors and gates that serve as part of an accessible means of egress.

Exceptions:

1. Low-energy automatic and full power automatic doors and gates that have standby power or battery back-up shall not be required to comply with section.
2. Low-energy automatic and full power automatic doors and gates that remain open in the power-off condition shall not be required to comply with this section.
3. Full power automatic sliding doors and gates that include a break-away feature shall not be required to comply with this section.

404.3.5 Thresholds. Thresholds and changes in level at doorways shall comply with Section 404.2.4.

404.3.6 Two doors or gates in series. Doors or gates in series shall comply with Section 404.2.5.

Exception:

Where both doors or gates in a series are low-energy automatic or full power automatic doors or gates, the two doors or gates in a series shall not be required to provide a turning space between the doors or gates.

404.3.8 Door and gate hardware. Handles, pulls, latches, locks and other operable parts shall comply with Section 404.2.6.

404.3.9 Break out opening. Where full power automatic sliding doors and gates are equipped with a break out feature, the clear break out opening shall be 32 inches (815 mm) minimum when operated in emergency mode.

2.6.3.1 Marking of transparent doors and fixed adjacent sidelights.

Transparent doors and fixed adjacent sidelights shall be marked in accordance with Section BC 2410 of the New York City Building Code (incorporated by reference in Section 1.3.5 and reproduced below).

SECTION BC 2410**MARKING OF TRANSPARENT DOORS AND FIXED ADJACENT TRANSPARENT SIDELIGHTS**

2410.1 Definitions. The following words and terms shall, for the purposes of this chapter and as used elsewhere in this code, have the meanings shown herein.

SIDELIGHTS. Fixed transparent panels which form part of or are immediately adjacent to and within 6 feet horizontally of the vertical edge of an opening in which transparent doors are located. A sidelight shall consist of transparent material in which the transparent area above a reference line 18 inches (457 mm) above the adjacent ground, floor or equivalent surface is 80 percent or more of the remaining area of the panel above such reference line.

TRANSPARENT. The property of a material which is not opaque and through which objects lying beyond are clearly visible.

TRANSPARENT DOOR. A door, manually or power actuated, fabricated of transparent material, in which the transparent area above a reference line 18 inches (457 mm) above the bottom edge of the door is 80 percent or more of the remaining area of the door above such reference line.

TRANSPARENT SAFETY GLAZING MATERIALS. Materials which will clearly transmit light and also minimize the possibility of cutting or piercing injuries resulting from breakage of the material. Materials covered by this definition include laminated glass, tempered glass (also known heat-treated glass, heat-toughened glass, case-hardened glass or chemically tempered glass), wired glass, and plastic glazing.

2410.2 Requirement. Transparent doors and fixed adjacent sidelights shall be marked in accordance with Sections BC 2410.3 through 2410.5.

EXCEPTIONS:

1. One-and two-family dwellings.
2. Fixed adjacent transparent sidelights 20 inches (508 mm) or less in width with opaque stiles at least 1¾ inches (44 mm) in width.
3. Where the ground, floor or equivalent surface area in the path of approach to a fixed adjacent transparent sidelight from either side for a minimum distance of 3 feet (914 mm) from such sidelight is so arranged, constructed or designed as to deter persons from approaching such sidelight or a permanent barrier is installed in the path of approach, provided that:

- 3.1 Decorative pools, horticultural planting or similar installations shall be considered as indicating that the ground, floor or equivalent surface area is not a path of approach.
- 3.2 Planters, benches and similar barriers which are securely fastened to the floor or wall to prevent their removal shall be considered as blocking the path of approach provided they shall be not less than 18 inches (457 mm) in height from the ground, floor or equivalent surface and extend across at least 2/3 of the total width of the glazed area of the sidelight.
4. Fixed adjacent transparent sidelights which are supported by opaque sill and wall construction of at least 18 inches.
5. Display windows in any establishment, building or structure which fall within the definition of a sidelight if the top of the supporting sill and wall construction is not less than 18 inches (457 mm) above the ground, floor or equivalent surface immediately adjacent and the interior area is occupied with merchandise or similar displays to clearly indicate to the public that it is not a means of ingress or egress.
6. Opaque door pulls or push bars extending across at least two-thirds of the total width of the glazed area.

2410.3 Locations. Transparent doors and fixed adjacent transparent sidelights shall be marked in two areas on the glass surface. One such area shall be located at least 30 inches (762 mm) but not more than 36 inches (914 mm) above the ground, floor or equivalent surface below the door or sidelight and the other at least 60 inches (1524 mm) but not more than 66 inches (1676 mm) above the ground, floor or equivalent surface below the door or sidelight.

Exception: The use of horizontal separation bars, muntin bars or other equivalent bars at least one and 1½ inches (38 mm) in vertical dimension that extend across the total width of the glazed area and are located at least 40 inches (1016 mm) but not more than 50 inches (1270 mm) above the bottom of the door or sidelight is permitted in lieu of markings.

2410.4 Design. The marking design shall be at least 4 inches (102 mm) in diameter if circular or 4 inches (102 mm) in its least dimension if elliptical or polygonal, or shall be at least 12 inches (305 mm) in horizontal dimension if the marking is less than 4 inches (102 mm) in its least dimension. In no event shall the vertical dimension of any marking including lettering be less than 1½ inches (38 mm) in height.

2410.5 Materials. Markings may be comprised of, but are not limited to:

1. Muntin bars, separation bars or other equivalent bars;
2. Chemical etching;
3. Sandblasting;
4. Adhesive strips;
5. Decals; or
6. Paint, gilding or other opaque marking materials.

2.7 Elevator Car Control Button Identification. Where elevators are required to be accessible by applicable building codes and standards, raised characters on elevator car control panels shall contrast with their background, either light-on-dark or dark-on-light, regardless of whether a visual character also is provided on the button.

2.8 Parking Meters and Pay Stations

2.8.1 General. Where parking meters and pay stations serve accessible parking spaces, the meters and pay stations shall comply with Section 2.8.

2.8.2 Operable parts. Parking meters and parking pay stations that serve parking spaces shall comply with Section 309 of the ICC A117.1 (incorporated by reference in Section 1.3.2).

2.8.3 Location. At parallel parking spaces, parking meters shall be located at the head or foot of the parking space.

2.8.4 Displays and information. Displays and information shall be visible from a point located 40 inches (1015 mm) maximum above the center of the clear space in front of the parking meter or parking pay station.

2.9 Electric Vehicle Charging Stations

2.9.1 General. Where provided, electric vehicle charging stations shall comply with Section 2.9.

Exception: Electric vehicle charging stations provided exclusively for fleet vehicles shall not be required to be accessible.

2.9.2 Number of accessible vehicle spaces. At least five percent (5%) of vehicle spaces on the site served by electrical vehicle charging systems (but not fewer than one for each type of electric vehicle charging system provided on the site) shall be accessible.

2.9.3 Technical requirements. Electrical vehicle charging stations shall comply with Section 2.9.3.

2.9.3.1 Vehicle space size. Accessible vehicle spaces shall comply with the requirements for van accessible parking spaces that are 132 inches (3350 mm) minimum in width with adjoining access aisles that are 60 inches (1525 mm) minimum in width.

2.9.3.2 Operable parts. Operable parts on the charging station intended for operation by the user, including card readers, shall comply with Section 309 of the ICC A117.1 (incorporated by reference in Section 1.3.2).

2.9.3.3 Accessible route. An accessible route shall be provided from the access aisle adjacent to the parking space to the clear floor space required to be adjacent to the vehicle charging station. When the vehicle is being charged, the accessible route shall not be obstructed by the cable between the car and charging station.

2.9.3.4 Obstructions. Protection bollards, curbs or wheel stops shall be located so that they do not obstruct the clear floor spaces at operable parts or required accessible routes.

2.10 Bus Boarding and Alighting Areas

2.10.1 General. Where provided in transportation facilities, bus boarding and alighting areas shall comply with Section 2.10.

2.10.2 Bus boarding and alighting areas shall be sized in accordance with Section 805.2.2 of the ICC A117.1 (incorporated by reference in Section 1.3.2 and reproduced below).

805.2.2 Dimensions

805.2.2.1 New buildings and facilities. In new buildings and facilities, bus stop boarding and alighting areas shall have a 100-inch (2540 mm) minimum clear length, measured perpendicular to the curb or vehicle roadway edge, and a 60-inch (1525 mm) minimum clear width, measured parallel to the vehicle roadway.

805.2.2.2 Existing buildings and facilities. In existing buildings and facilities, bus stop boarding and alighting areas shall have a 96-inch (2440 mm) minimum clear length, measured perpendicular to the curb or vehicle roadway edge, and a 60-inch (1525 mm) minimum clear width, measured parallel to the vehicle roadway.

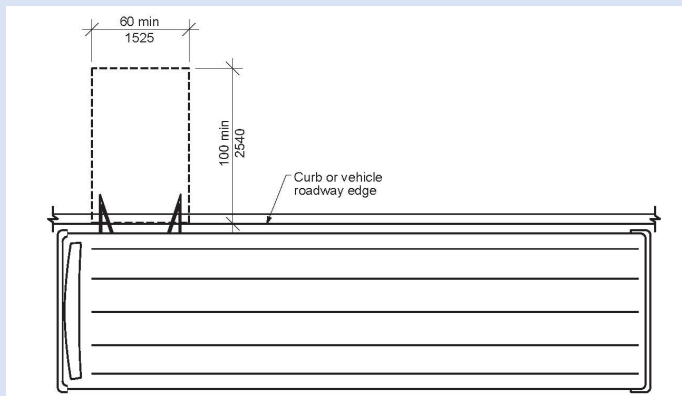

**FIGURE 805.2.2(A)
SIZE OF BUS BOARDING AND ALIGHTING AREA – NEW BUILDINGS**

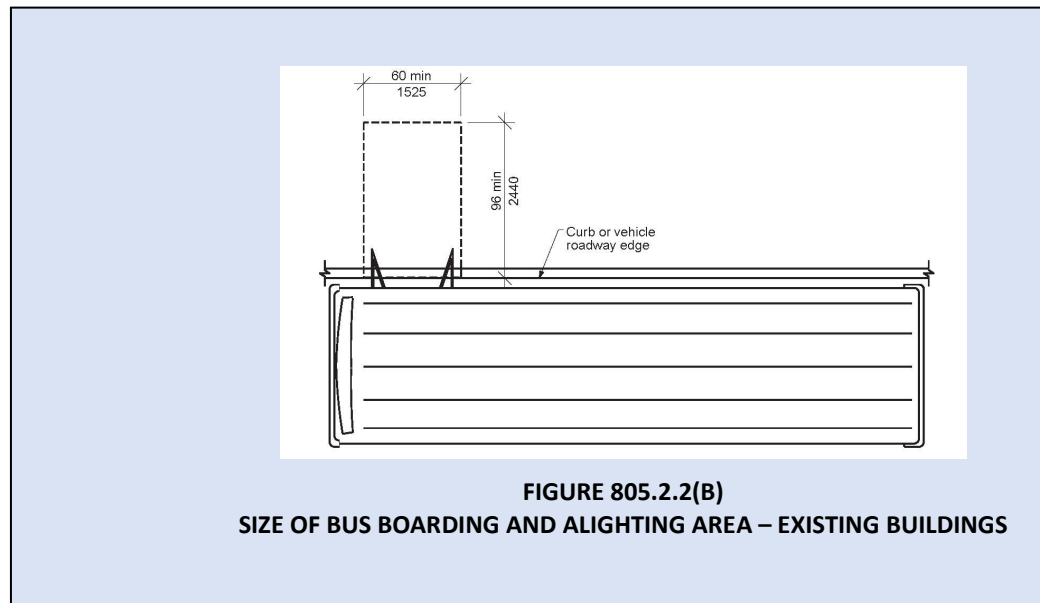

2.11 Stairs and Ramps

2.11.1 General. Stairs and ramps required to be accessible by applicable building codes and standards shall comply with Section 2.11 to the extent that these requirements do not conflict with enforceable building codes or applicable ANSI safety standards.

2.11.2 Stair tread markings. Stairs that are part of a required means of egress from a public use area shall provide tread markings with visual contrast complying with either 1 or 2:

1. The leading 1 to 2 inches (25 to 51 mm) of every tread and landing, measured horizontally from the leading edge of the nosing, shall consist of a solid color having visual contrast of light-on-dark or dark-on-light or from the remainder of the tread. The contrasting marking shall be durable and shall extend from one side of each tread to the other side of each tread.
2. Durable distinctive warning markings required by the applicable building code or ANSI safety standard.

Exception: Monumental stairs are not required to provide stair tread markings.

2.11.3 Stair and ramp illumination. Maintained emergency illumination levels on interior and exterior exit access stairs and ramps from public use areas in transportation facilities shall be an average of 2 footcandles (22 lux) and a minimum at any point of 0.2 footcandles (2 lux) measured along the path of egress at floor level, with a 20:1 max/min ratio.

2.12 Bottle Filling Stations

2.12.1 General. Where bottle filling stations are provided, they shall be accessible in accordance with Section 602.4 of the ICC A117.1 (incorporated by reference in Section 1.3.2 and reproduced below).

602.4 Bottle filling stations. Bottle filling stations shall comply with Sections 602.4.1 and 602.4.2.

Exception: Where bottle filling stations are part of the drinking fountain for persons who are standing, the bottle filling station is not required to comply with this section provided a bottle filling station is located at the drinking fountain for persons using wheelchairs.

602.4.1 Clear floor space. A clear floor space positioned for a forward or side approach shall be provided.

602.4.2 Controls. Controls for bottle filling stations shall be hand operated or automatic. Hand operated controls shall comply with Section 309.

2.13 Adult Changing Stations

2.13.1 General. Adult changing stations shall be provided in accordance with Section 2.13.

2.13.2 Where required. Where family or assisted-use toilet or bathing rooms are required by applicable building codes and standards to be provided in airport, bus, rail, or ferry facilities, at least one such toilet or bathing room within each pre-security area and each passenger area associated with a group of gates, such as a concourse or pier, shall provide an adult changing station. Access to family or assisted-use toilet or bathing rooms containing adult changing stations shall not require users to pass through security checkpoints.

Exceptions:

1. In areas where family or assisted-use toilet or bathing rooms are not provided, access to family or assisted-use toilet or bathing rooms containing adult changing stations shall be permitted to require users to pass through security checkpoints.

2. In alterations, where the provision of an adult changing station would require the removal of required fixtures or would require an expansion of the gross floor area, an adult changing station shall not be required.

2.13.3 Technical requirements. Adult changing stations shall comply with Section 2.13.3.

2.13.3.1 Changing Surface. Changing surfaces shall comply with Section 2.13.3.1.

2.13.3.1.1 Size. Adult changing stations shall have a changing surface 28 inches (711 mm) minimum in width and 70 inches (1778 mm) minimum in length.

2.13.3.1.2 Material: The changing surface shall be comprised of hard, non-porous, non-absorbent, durable materials that are resistant to damage and discoloration by cleaning products listed on the U.S. Environmental Protection Agency List N: *Disinfectants for Use Against SARS-CoV-2 (COVID-19)*.

2.13.3.2 Clearances. Clearances shall be provided in accordance with Section 2.13.3.2.

2.13.3.2.1 Side clearance. A 36 inches (914 mm) wide minimum clearance shall be provided adjacent to the full length of one side of the changing surface, measured at the outermost points of the changing station, including supporting structure.

2.13.3.2.2 Head, foot, and side clearance. A 36 inches (914 mm) wide minimum clearance shall be provided at the head and foot ends of the changing station and shall extend the full table width, plus the width of the side clearance.

2.13.3.2.3 Floor surfaces with clearances. Floor surfaces within clearances shall be stable, firm, slip resistant, and nominally planar. Changes in level within clearances greater than 1/4-inch (6.4 mm) in height and not more than 1/2-inch (13 mm) maximum in height shall be beveled with a slope not steeper than 1:2. Changes in level greater than 1/2-inch shall not be permitted.

- 2.13.3.3 Height adjustability.** Changing stations shall be continuously height adjustable from 17 inches (432 mm) maximum above the floor to 38 inches (965 mm) minimum above the floor, as measured to the top of the changing surface. Operable parts shall comply with Section 309 of the ICC A117.1 (incorporated by reference in Section 1.3.2).
- 2.13.3.4 Capacity.** Changing stations shall support 300 pounds (136 kg) minimum applied at any point on the changing surface. Allowable stresses shall not be exceeded for the materials used.
- 2.13.3.5 Stability.** Changing stations shall be secured to the floor, wall, or both.
- 2.13.3.6 Accessible routes.** When not in use, changing stations shall not obstruct the required width of accessible routes.

2.14 Water Closets and Toilet Compartments

- 2.14.1 General.** Water closets and toilet compartments required to be accessible by applicable building codes and standards shall comply with Section 2.14.
- 2.14.2 Toilet compartments: minimum number and type.** Where toilet compartments are provided in a toilet room or bathing room, at least 5 percent, but no less than one, of the total number of toilet compartments shall be wheelchair accessible. Except in toilet rooms provided for children's use, where two or more wheelchair accessible toilet compartments are required, at least one shall be sized in accordance with Section 604.9.2.1 of ICC A117.1 (incorporated by reference in Section 1.3.2 and reproduced below) and at least one shall be sized in accordance with Section 604.9.2.3 of the ICC A117.1 (incorporated by reference in Section 1.3.2 and reproduced below). Where the combined total water closet compartments and urinals provided in a toilet room or bathing room is six or more, at least 5 percent, but no less than one, of the total number of compartments shall be ambulatory accessible, and shall be provided in addition to the wheelchair accessible compartment(s).
- 2.14.3 Technical requirements.** Water closets and toilet compartments shall comply with Section 604 of the ICC A117.1 (incorporated by reference in Section 1.3.2 and reproduced below).

SECTION 604

WATER CLOSETS AND TOILET COMPARTMENTS

604.1 General. Water closets and toilet compartments shall comply with Section 604. Compartments containing more than one plumbing fixture shall comply with Section 603. Wheelchair accessible compartments shall comply with Section 604.9. Ambulatory accessible compartments shall comply with Section 604.10.

Exception: Water closets and toilet compartments primarily for children’s use shall be permitted to comply with Section 604.11 as applicable.

604.2 Location. The water closet shall be located with a wall or partition to the rear and to one side. The centerline of the water closet shall be 16 inches (405 mm) minimum and 18 inches (455 mm) maximum from the side wall or partition. Water closets located in ambulatory accessible toilet compartments specified in Section 604.10 shall have the centerline of the water closet 17 inches (430 mm) minimum and 19 inches (485 mm) maximum from the side wall or partition.

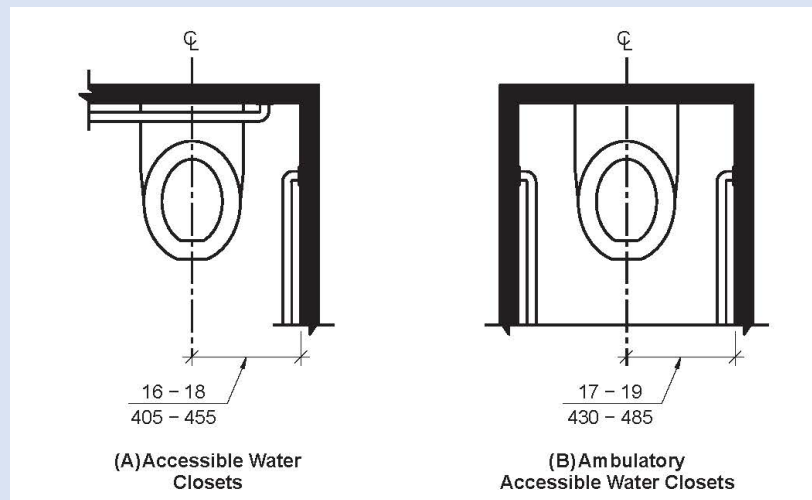

FIGURE 604.2
WATER CLOSET LOCATION

604.3 Clearance.

604.3.1 Clearance width. Clearance around a water closet shall be 60 inches (1525 mm) minimum in width, measured perpendicular from the sidewall.

604.3.2 Clearance depth. Clearance around the water closet shall be 56 inches (1420 mm) minimum in depth, measured perpendicular from the rear wall.

604.3.3 Clearance overlap. The required clearance around the water closet shall be permitted to overlap the water closet, associated grab bars, paper dispensers, sanitary napkin receptacles, coat hooks, shelves, accessible routes, clear floor space at other fixtures and the turning space. No other fixtures or obstructions shall be within the required water closet clearance.

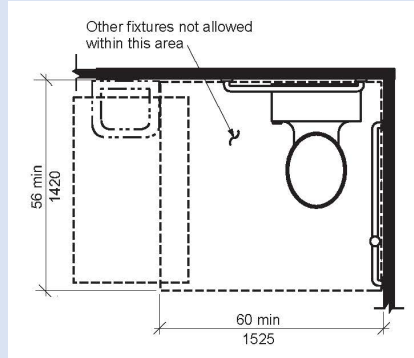

FIGURE 604.3
SIZE OF CLEARANCE FOR WATER CLOSET

604.4 Height. The height of water closet seats shall be 17 inches (430 mm) minimum and 19 inches (485 mm) maximum above the floor, measured to the top of the seat. Seats shall not be sprung to return to a lifted position.

Exceptions:

1. A water closet which is adjustable in height by the user is permitted provided that at least one adjustment setting provides a seat within the range specified in this section.
2. A water closet which is adjustable in height by the user is permitted provided that at least one adjustment setting provides a seat within the range specified in this section.

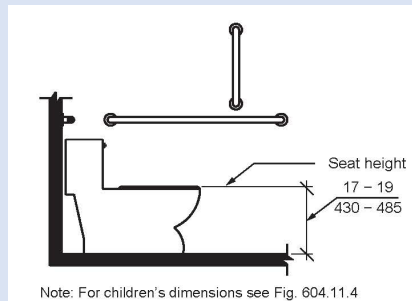

FIGURE 604.4
WATER CLOSET SEAT HEIGHT

604.5 Grab bars. Grab bars for water closets shall comply with Section 609 and shall be provided in accordance with Sections 604.5.1 and 604.5.2. Grab bars shall be provided on the rear wall and on the side wall closest to the water closet.

Exceptions:

1. Grab bars shall not be required to be installed in a toilet room for a single occupant, accessed only through a private office and not for common use or public use, provided reinforcement has been installed in walls and located so as to permit the installation of grab bars complying with Section 604.5.
2. In detention or correction facilities, grab bars shall not be required to be installed in housing or holding cells or rooms that are specially designed without protrusions for purposes of suicide prevention.

604.5.1 Fixed side-wall grab bars. Fixed side-wall grab bars shall include a horizontal bar complying with Section 604.5.1.1 and a vertical grab bar complying with Section 604.5.1.2. The vertical grab bar at water closets primarily for children's use shall comply with Section 609.4.2.

604.5.1.1 Horizontal grab bar. A horizontal grab bar 42 inches (1065 mm) minimum in length shall be located 12 inches (305 mm) maximum from the rear wall and extend 54 inches (1370 mm) minimum from the rear wall.

604.5.1.2 Vertical grab bar. A vertical grab bar 18 inches (455 mm) minimum in length shall be mounted with the bottom of the bar located 39 inches (990 mm) minimum and 41 inches (1040 mm) maximum above the floor, and with the center line of the bar located 39 inches (990 mm) minimum and 41 inches (1040 mm) maximum from the rear wall.

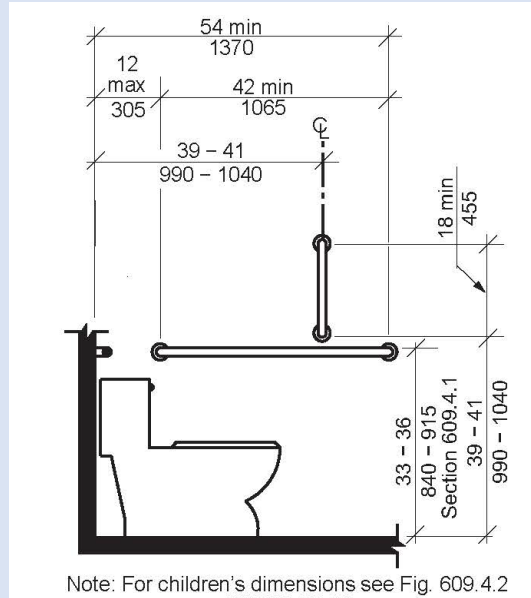

FIGURE 604.5.1
SIDE-WALL GRAB BAR FOR WATER CLOSET

604.5.2 Rear-wall grab bars. The fixed rear-wall grab bars shall

1. Be 36 inches (915 mm) minimum in length,
2. Be located 6 inches maximum (150 mm) from the side wall, and
3. Extend 42 inches (1065 mm) minimum from the side wall.

Exceptions:

1. The rear grab bar shall be permitted to be 24 inches (610 mm) minimum in length, centered on the water closet, where wall space does not permit a grab bar 36 inches (915 mm) minimum in length due to the location of a recessed fixture adjacent to the water closet.
2. Where an administrative authority requires flush controls for flush valves to be located in a position that conflicts with the location of the rear grab bar, that grab bar shall be permitted to be split or shifted to the open side of the toilet area.

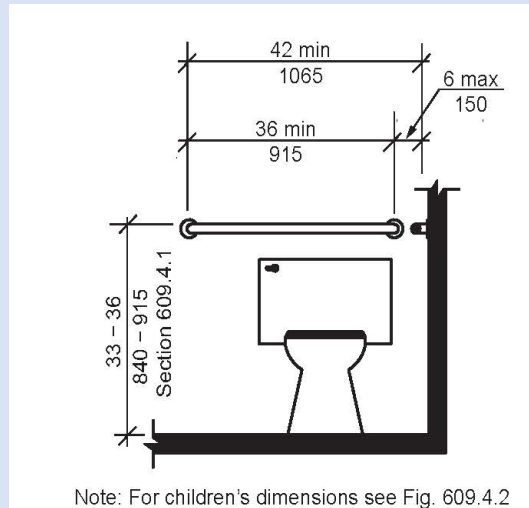

FIGURE 604.5.2
REAR-WALL GRAB BAR FOR WATER CLOSET

604.6 Flush controls. Flush controls shall be hand operated or automatic. Hand operated flush controls shall comply with Section 309. Flush controls shall be located on the open side of the water closet.

Exception: In ambulatory accessible toilet compartments complying with Section 604.10, flush controls shall be permitted to be located on either side of the water closet.

604.7 Dispensers. Toilet paper dispensers shall comply with Sections 309.4 and 609.3. Dispensers shall not be of a type that control delivery or do not allow continuous paper flow.

604.7.1 Location. Where the dispenser is located above the grab bar, the outlet of the dispenser shall be located within an area 24 inches (610 mm) minimum and 36 inches (915 mm) maximum from the rear wall. Where the dispenser is located below the grab bar, the outlet of the dispenser shall be located 18 inches (455 mm) minimum and 48 inches (1220 mm) maximum above the floor.

Exception: Toilet paper dispensers that accommodate a maximum of 2 toilet paper rolls of not more than 5-inch (125 mm) diameter each shall be permitted to be located 7 inches (180 mm) minimum and 9 inches (230 mm) maximum in front the of the water closet measured to the centerline of the dispenser. The outlet of the dispenser shall be 15 inches (380 mm) minimum and 48 inches (1220 mm) maximum above the floor.

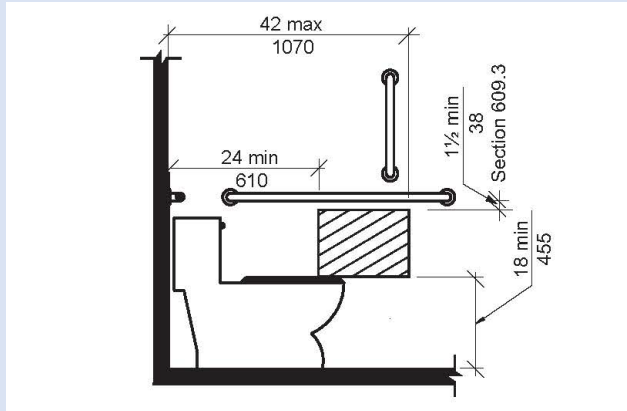

FIGURE 604.7.1(A)
DISPENSER OUTLET LOCATION - PROTRUDING DISPENSER
BELOW GRAB BAR

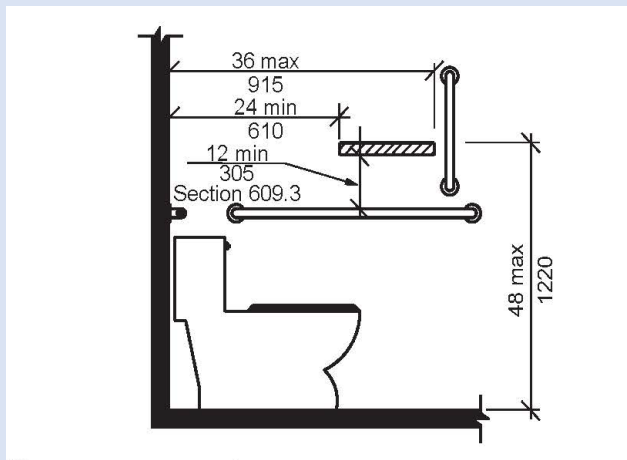
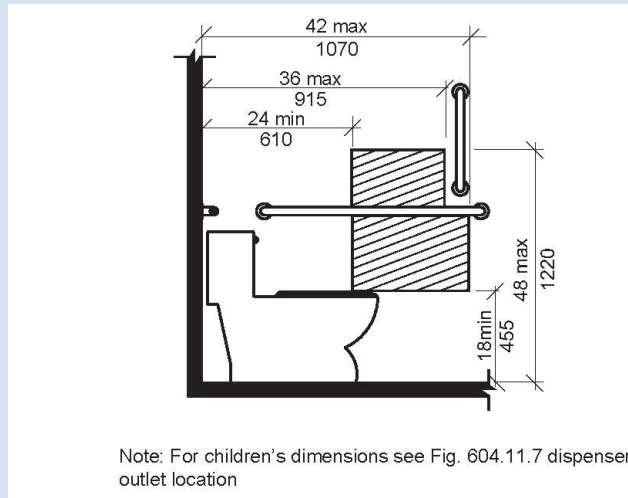
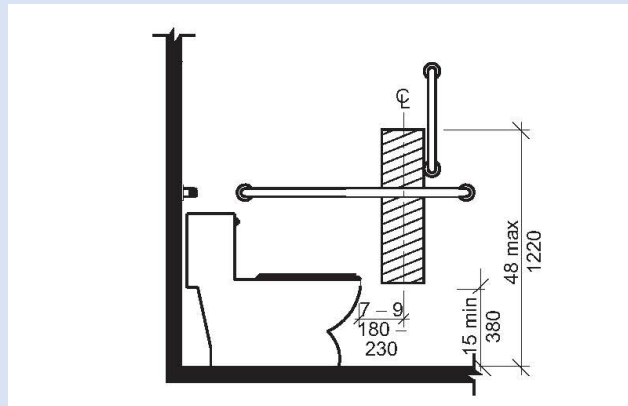

FIGURE 604.7.1(B)
DISPENSER OUTLET LOCATION - PROTRUDING DISPENSER
ABOVE GRAB BAR



**FIGURE 604.7.1(C)
DISPENSER OUTLET LOCATION – RECESSED DISPENSER**



**FIGURE 604.7.1(D)
DISPENSER OUTLET LOCATION -
DISPENSER IN FRONT OF WATER CLOSET – EXCEPTION**

604.8 Coat hooks and shelves. Coat hooks provided within toilet compartments shall be 48 inches (1220 mm) maximum above the floor. Shelves shall be 40 inches (1015 mm) minimum and 48 inches (1220 mm) maximum above the floor.

604.9 Wheelchair accessible toilet compartments.

604.9.1 General. Wheelchair accessible toilet compartments shall comply with Section 604.9.

604.9.2 Size. Wheelchair accessible toilet compartments shall comply with Section 604.9.2.1, 604.9.2.2 or 604.9.2.3 as applicable.

604.9.2.1 Minimum area. The minimum area of a wheelchair accessible toilet compartment shall be 60 inches (1525 mm) minimum in width measured perpendicular to the side wall, and 56 inches (1420 mm) minimum in depth for wall hung water closets, and 59 inches (1500 mm) minimum in depth for floor mounted water closets measured perpendicular to the rear wall.

604.9.2.2 Compartment for children’s use. The minimum area of a wheelchair accessible toilet compartment primarily for children’s use shall be 60 inches (1525 mm) minimum in width measured perpendicular to the side wall, and 59 inches (1500 mm) minimum in depth for wall hung and floor mounted water closets measured perpendicular to the rear wall.

604.9.2.3 Alternate wheelchair accessible toilet compartments. Where an alternate wheelchair accessible toilet compartment is provided, the minimum area of the compartment shall be 60 inches (1525 mm) minimum in width, measured perpendicular to the side wall, and 84 inches (2135 mm) minimum in depth, measured perpendicular to the rear wall.

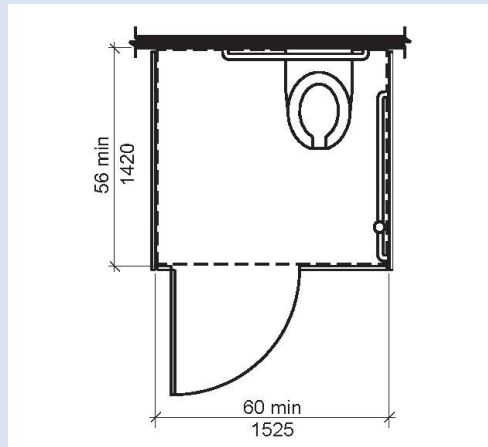

**FIGURE 604.9.2(A)
WHEELCHAIR TOILET COMPARTMENTS – WALL HUNG CLOSET, ADULT**

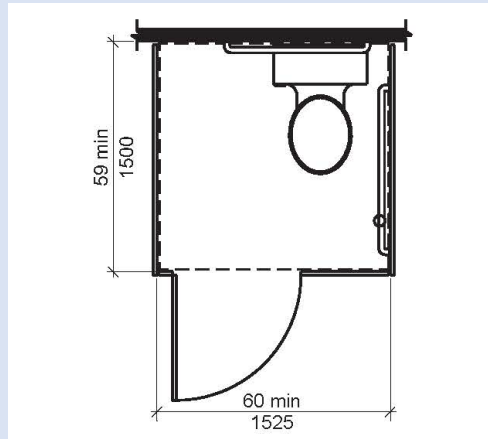

FIGURE 604.9.2(B)
**WHEELCHAIR TOILET COMPARTMENTS – FLOOR MOUNTED CLOSET, ADULT
WALL HUNG AND FLOOR MOUNTED WATER CLOSET, CHILDREN**

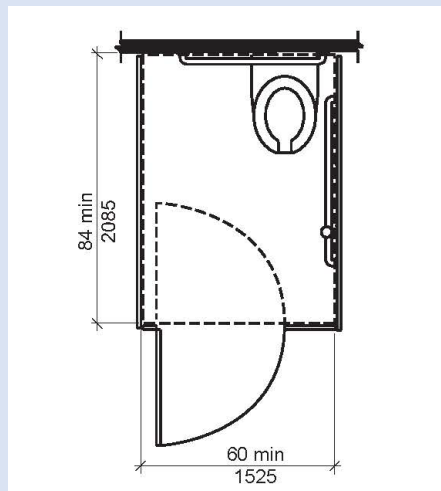

FIGURE 604.9.2.3
**WHEELCHAIR TOILET COMPARTMENTS
ALTERNATE WHEELCHAIR TOILET COMPARTMENT**

604.9.3 Doors. Wheelchair accessible toilet compartment doors, including door hardware, shall comply with Section 404. The door shall be self-closing. A door pull complying with Section 404.2.6 shall be placed on both sides of the door near the latch. Wheelchair accessible toilet compartment doors shall not swing into the required minimum area of the compartment.

Exceptions:

1. Outside of the compartment, where the approach is to the latch side of the wheelchair accessible toilet compartment, door clearance between the door side of the compartment and any obstruction shall be 42 inches (1065 mm) minimum.
2. Within the wheelchair accessible toilet compartment, maneuvering clearances at the door shall not be required to comply with Section 404.
3. In an alternate wheelchair accessible toilet compartment, the door shall be permitted to swing into the stall where a clear floor space complying with Section 305.3 is provided within the stall beyond the arc of the door swing.

604.9.3.1 Door opening location. The farthest edge of the wheelchair accessible toilet compartment door opening shall be located in the front wall or partition or in the side wall or partition as required by Table 604.9.3.1.

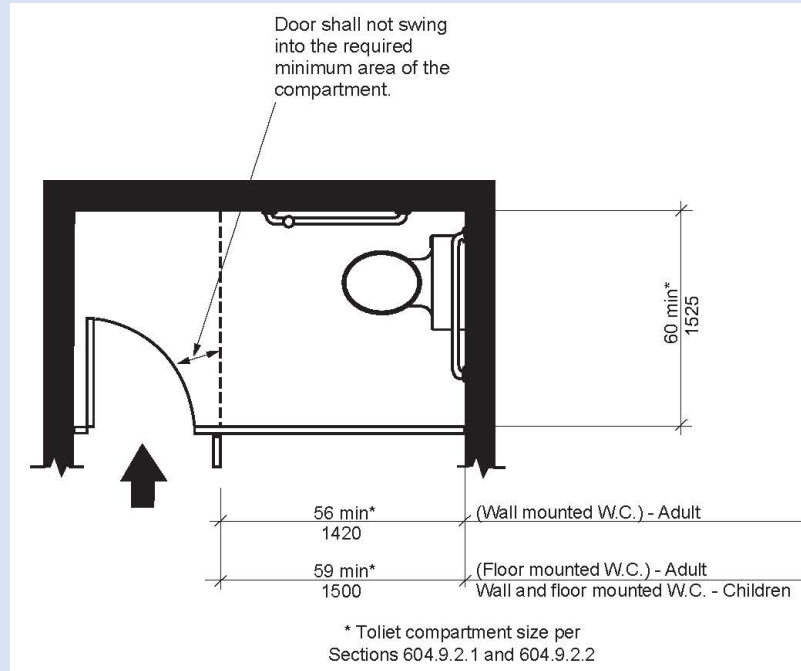

FIGURE 604.9.3(A)
WHEELCHAIR TOILET COMPARTMENT DOORS
DOOR SWINGING INTO THE WHEELCHAIR TOILET COMPARTMENT

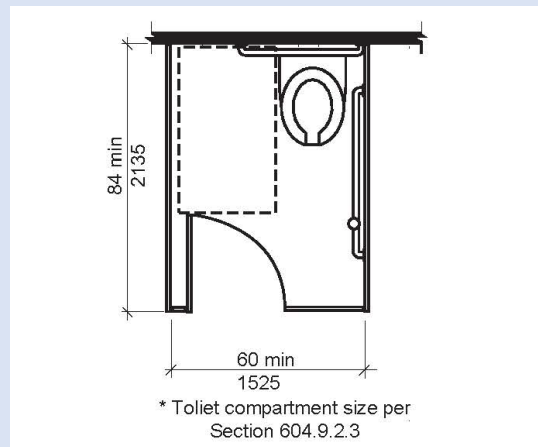

FIGURE 604.9.3(B)
WHEELCHAIR TOILET COMPARTMENT DOORS
EXCEPTION 3 – ALTERNATE WHEELCHAIR TOILET COMPARTMENT

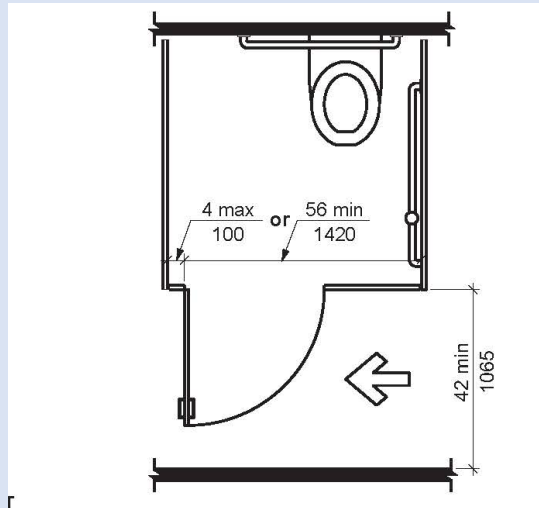

FIGURE 604.9.3.1(A)
WHEELCHAIR TOILET COMPARTMENT DOOR OPENING
LOCATION – DOOR SWINGING IN ON FRONT WALL OF PARTITION

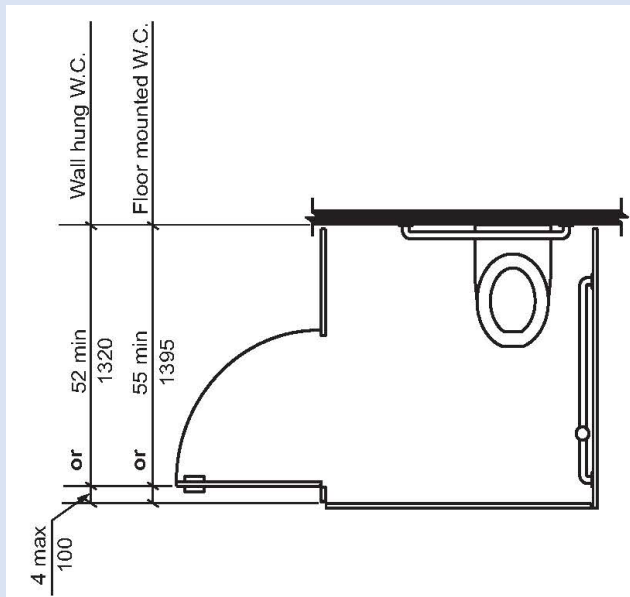

FIGURE 604.9.3.1(B)
WHEELCHAIR TOILET COMPARTMENT DOOR OPENING LOCATION
DOOR SWINGING IN ON SIDE WALL OF PARTITIONS

TABLE 604.9.3.1 – DOOR OPENING LOCATION

Door Opening Location	Measured From:	Dimensions
Front Wall or Partition	From the side wall or partition closest to the water closet	36 inches (1420 mm) minimum
	or	
	From the side wall or partition farthest from the water closet	4 inches (100 mm) maximum
Side Wall or Partition Wall-Hung Water Closet	From the rear wall	52 inches (1320 mm) minimum
	or	
	From the front wall or partition	4 inches (100 mm) maximum
Side Wall or Partition Floor-Mounted Water Closet	From the rear wall	55 inches (1395 mm) minimum
	or	
	From the front wall or partition	4 inches (100 mm) maximum

604.9.4 Approach. Wheelchair accessible toilet compartments shall be arranged for left-hand or right-hand approach to the water closet.

604.9.5 Toe clearance. Toe clearance for wheelchair accessible toilet compartments primarily for children’s use shall comply with Section 604.9.5.2. Toe clearance for other wheelchair accessible toilet compartments shall comply with Section 604.9.5.1.

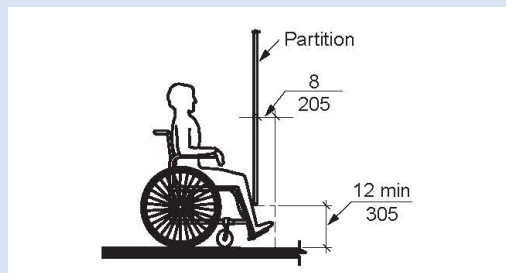

**FIGURE 604.9.5 (A)
TOE CLEARANCE – ELEVATION**

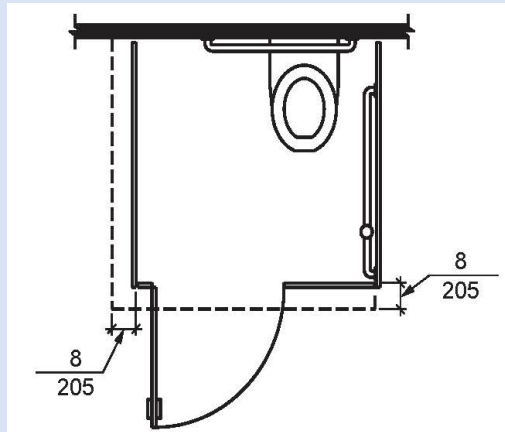

FIGURE 604.9.5 (B)
TOE CLEARANCE – PLAN

604.9.5.1 Toe clearance at wheelchair accessible toilet compartments. The front partition and at least one side partition of wheelchair accessible toilet compartments shall provide a toe clearance of 12 inches (305 mm) minimum above the floor and extending 8 inches (205 mm) beyond the compartment side face of the partition, exclusive of partition support members.

Exceptions:

1. Toe clearance at the front partition is not required in a wheelchair accessible toilet compartment greater than 64 inches (1625 mm) in depth with a wall-hung water closet, or greater than 67 inches (1700 mm) in depth with a floor-mounted water closet.
2. Toe clearance at the side partition is not required in a wheelchair accessible toilet compartment greater than 68 inches (1725 mm) in width.

604.9.5.2 Toe clearance at wheelchair accessible toilet compartments for children's use. The front partition and at least one side partition of wheelchair accessible toilet compartments primarily for children's use shall provide a toe clearance of 12 inches (305 mm) minimum above the floor and extending 8 inches (205 mm) beyond the wheelchair accessible toilet compartment side face of the partition, exclusive of partition support members.

Exceptions:

1. Toe clearance at the front partition is not required in a wheelchair accessible toilet compartment greater than 67 inches (1700 mm) in depth.
2. Toe clearance at the side partition is not required in a wheelchair accessible toilet compartment greater than 68 inches (1725 mm) in width.

604.9.6 Grab bars. Grab bars shall comply with Section 609. Side wall grab bars complying with Section 604.5.1 located on the wall closest to the water closet, and a rear wall grab bar complying with Section 604.5.2, shall be provided.

604.10 Ambulatory accessible toilet compartments.

604.10.1 General. Ambulatory accessible toilet compartments shall comply with Section 604.10.

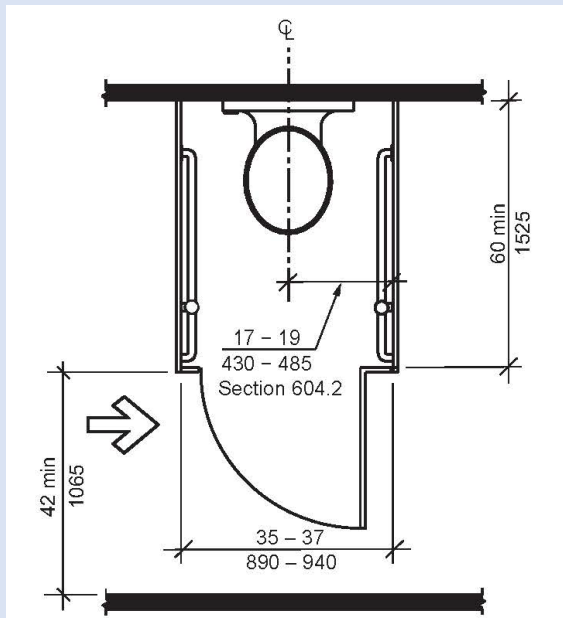

**FIGURE 604.10.1
AMBULATORY COMPARTMENT**

604.10.2 Size. The minimum area of an ambulatory accessible toilet compartment shall be 60 inches (1525 mm) minimum in depth and a width of 35 inches (890 mm) minimum and 37 inches (940 mm) maximum.

604.10.3 Doors. Ambulatory accessible toilet compartment doors, including door hardware, shall comply with Section 404. The door shall be self-closing. A door pull complying with Section 404.2.6 shall be

placed on both sides of the door near the latch. Compartment doors shall not swing into the required minimum area of the compartment

Exceptions:

1. Outside of the ambulatory accessible toilet compartment, where the approach is to the latch side of the compartment door, clearance between the door side of the compartment and any obstruction shall be 42 inches (1065 mm) minimum.
2. Within the ambulatory accessible toilet compartment, maneuvering clearances at the door shall not be required to comply with Section 404.

604.10.4 Grab bars. Grab bars shall comply with Section 609. Side wall grab bars complying with Section 604.5.1 shall be provided on both sides of the compartment.

604.11 Water closets and toilet compartments for children’s use.

604.11.1 General. Water closets and wheelchair and ambulatory accessible toilet compartments primarily for children’s use shall comply with Section 604.11.

604.11.2 Location. The water closet shall be located with a wall or partition to the rear and to one side. The centerline of the water closet shall be 12 inches (305 mm) minimum and 18 inches (455 mm) maximum from the side wall or partition. Water closets located in ambulatory accessible toilet compartments specified in Section 604.10 shall be located as specified in Section 604.2.

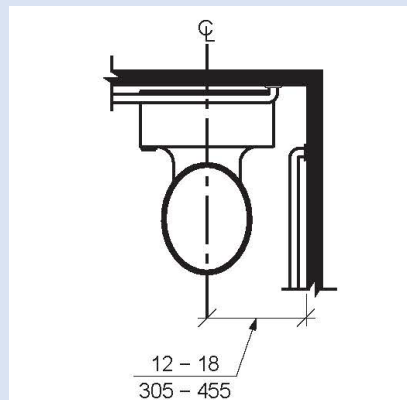

FIGURE 604.11.2
CHILDREN’S WATER CLOSET LOCATION

604.11.3 Clearance. A clearance around the water closet complying with Section 604.3 shall be provided.

604.11.4 Height. The height of water closet seats shall be 11 inches (280 mm) minimum and 17 inches (430 mm) maximum above the floor, measured to the top of the seat. Seats shall not be sprung to return to a lifted position.

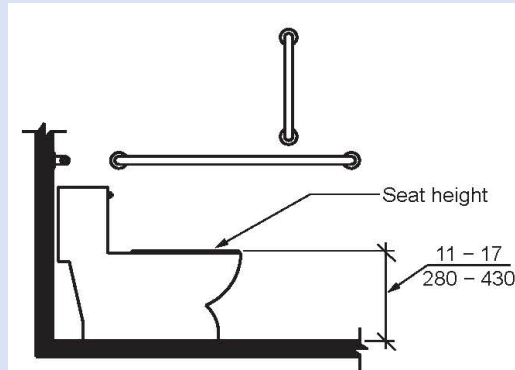

FIGURE 604.11.4
CHILDREN'S WATER CLOSET HEIGHT

604.11.5 Grab bars. Grab bars for water closets shall comply with Section 604.5.

604.11.6 Flush controls. Flush controls shall be hand operated or automatic. Hand operated flush controls shall comply with Sections 309.2 and 309.4 and shall be installed 36 inches (915 mm) maximum above the floor. Flush controls shall be located on the open side of the water closet.

Exception: In ambulatory accessible toilet compartments complying with Section 604.10, flush controls shall be permitted to be located on either side of the water closet.

604.11.7 Dispensers. Toilet paper dispensers shall comply with Section 309.4. Dispensers shall not be of a type that control delivery or do not allow continuous paper flow.

604.11.7.1 Location. The outlet of toilet paper dispensers shall be located within an area 24 inches (610 mm) minimum and 42 inches (1065 mm) maximum from the rear wall. The outlet of the dispenser shall be 14 inches (355 mm) minimum and 19 inches (485 mm) maximum above the floor.

Exception: Toilet paper dispensers that accommodate a maximum of 2 toilet paper rolls of not more than 5-inch diameter each shall be permitted to be located 7 inches minimum and 9 inches maximum in front of the of the water closet measured to the centerline of the dispenser. The outlet of the dispenser shall be 14 inches (355 mm) minimum and 19 inches (485 mm) maximum above the floor.

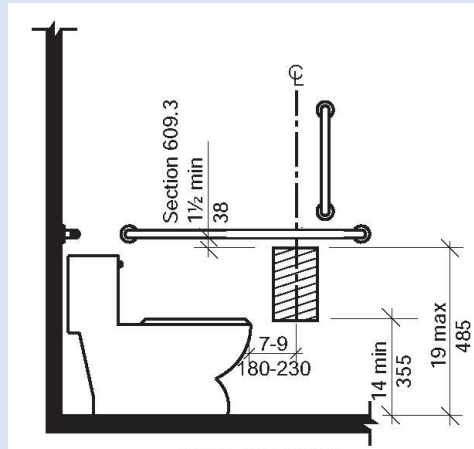

**FIGURE 604.11.7(B)
CHILDREN'S DISPENSER OUTLET – EXCEPTION**

2.15 Toilet Rooms

- 2.15.1 General.** Entries and exits to toilet rooms shall comply with 2.15.2. Family or assisted use toilet rooms shall comply with 2.15.3.
- 2.15.2 Entries and exits.** Each toilet room with an aggregate of ten (10) or more male or female water closets shall provide a doorless entry and exit or shall provide full powered automatic doors complying with ANSI/BHMA A156.10 (incorporated by reference in Section 1.3.1).
- 2.15.3 Privacy in family or assisted use toilet rooms.** Doors to family or assisted-use toilet and bathing rooms shall be securable from within the room and shall be provided with an "occupied" indicator.

2.16 Showers: Grab Bars and Hand Shower

2.16.1 General. Where required to be accessible by applicable building codes and standards, grab bars in standard roll-in type showers shall comply with Section 2.16.2 and hand showers in alternate-type roll-in showers shall comply with Section 2.16.3.

2.16.2 Grab bars in roll-in type showers. Grab bars in standard roll-in type showers shall comply with Sections 608.3.2 through 608.3.3 of the ICC A117.1 (incorporated by reference in Section 1.3.2 and reproduced below).

608.3.2 Standard roll-in-type showers. Grab bars in standard roll-in showers shall comply with Sections 608.3.2.1 through 608.3.2.3.

608.3.2.1 Back-wall grab bar. In standard roll-in type showers, a grab bar shall be provided on the back wall beginning at the edge of the seat. The grab bars shall not be provided above the seat. The back-wall grab bar shall extend the length of the wall and extend within 6 inches (150 mm) maximum from the adjacent side wall opposite the seat.

EXCEPTIONS:

1. The back-wall grab bar shall not be required to exceed 48 inches (1220 mm) in length.
2. The back-wall grab bar is not required to extend within 6 inches (150 mm) of the adjacent side wall opposite the seat if it would require the grab bar length to exceed 48 inches (1220 mm) in length.

608.3.2.2 Side-wall grab bars. Where a side wall is provided opposite the seat within 72 inches (1830 mm) of the seat wall, a grab bar shall be provided on the side-wall opposite the seat. The side wall grab bar shall extend the length of the wall and extend within 6 inches (150 mm) maximum from the adjacent back wall.

EXCEPTION: The side-wall grab bar shall not be required to exceed 30 inches (760 mm) in length.

608.3.2.3 Vertical grab bar. Where a side wall is provided opposite the seat within 72 inches (1830 mm) of the seat wall a vertical grab bar shall be provided. A vertical grab bar 18 inches (455 mm) minimum in length shall be provided on the end wall 3 inches (75mm) minimum and 6 inches (150 mm) maximum above the horizontal grab bar, and 4 inches (100 mm) maximum inward from the front edge of the shower.

608.3.3 Alternate roll-in-type showers. In alternate roll-in type showers, grab bars shall be provided on the back wall and the side wall adjacent to the seat. Grab bars shall not be provided above the seat. Grab bars shall be 6 inches (150 mm) maximum from the adjacent wall.

2.16.3 Hand showers. Hand showers in alternate roll-in showers shall be located in accordance with Section 608.4.3 of the ICC A117.1 (incorporated by reference in Section 1.3.2 and reproduced below).

608.4.3 Alternate roll-in showers. In alternate roll-in showers, the controls and hand shower shall be located.

1. At a height of 38 inches (965 mm) minimum and 48 inches (1220 mm) maximum above the shower floor; and
2. Where the controls and hand shower are located on the end wall adjacent to the seat, the controls and hand shower shall be 16 inches (405 mm) minimum and 27 inches (685 mm) maximum from the wall behind the seat wall; or
3. Where the controls and hand shower are located on the back wall opposite the seat, the controls and hand shower shall be located within 15 inches (380 mm) maximum from the centerline of the seat toward the transfer space.

2.17 Sauna and Steam Room Doors

2.17.1 General. Where saunas and steam rooms for individual use are required to be accessible by applicable building codes and standards, doors into such rooms shall be permitted to swing into the clear floor space required to be located at the end of the bench seat and parallel to its short axis, provided that the sauna or steam room provides a clear floor space complying with Section 2.2.3 located within the room beyond the arc of the door swing.

2.18 Kitchen Sinks

2.18.1 General. Where non-commercial employee kitchens (employee break rooms and kitchenettes) are required to be accessible by applicable building codes and standards, kitchen sinks shall provide a clear floor space complying with Section 2.2.3 positioned for a forward approach with knee and toe clearance complying with Section 306 of the ICC A117.1 (incorporated by reference in Section 1.3.2) beneath the sink regardless of whether a conventional range or cooktop is provided.

2.19 Signs

2.19.1 General. Signs required to be accessible by applicable building codes and standards shall comply with Section 2.19.

2.19.2 Nonglare finish. The glare from coverings, the finish of characters, pictograms, and symbols and their background shall not exceed 19 gloss units (gu) as measured on a 60-degree gloss meter.

2.19.3 Toilet room signs. Signs that designate or provide directions to toilet rooms, including toilet rooms that are not accessible, shall provide pictograms complying with complying with ISO 7001 (incorporated by reference in Section 1.3.4) as follows:

1. Symbol PI-PF 003 shall be used on signs indicating that toilets are for the use of males or females, or are not gender specific;
2. Symbol PI-PF 004 shall be used on signs indicating that toilets are for the use of males; and
3. Symbol PI-PF 005 shall be used on signs indicating that toilets are for the use of females.

2.19.4 Hearing loop signs. Facilities required by Section 2.20 to provide hearing loops shall provide a sign notifying building occupants of the availability of a hearing loop. Such signs shall comply with Figure 2.19.3.

Exception: Additional messages to aid the customer to use the loop system shall be permitted to be included on the sign.



**FIGURE 2.19.3
HEARING LOOP SYMBOL**

2.20 Hearing Loops (Induction loop-type Assistive Listening)

2.20.1 General. Hearing loops (induction loop-type assistive listening systems) shall comply with 2.20.

2.20.2 Where required. Airports, bus, rail, and ferry facilities shall provide hearing loops (induction loop-type assistive listening) in accordance with Section 2.20.2.

Exceptions: Receivers shall not be required for hearing loops required at the locations specified in Sections 2.20.2, or where voluntarily provided at sales and service counters and windows, airline lounges and clubs, restaurants, concourses, or similar spaces where an assistive listening system is not required by applicable building codes and standards.

2.20.2.1 Information counters. Airport, bus, rail, and ferry facilities that provide staffed traveler information counters shall provide a hearing loop system for each such counter to facilitate communication between the staff and a customer.

2.20.2.2 Passenger gates. Airport passenger terminals shall provide a hearing loop system for each passenger gate. Each system shall be designed to transmit all audible public address announcements broadcast to the gate it serves.

Exception: In alterations to existing passenger gates, hearing loops are not required to be installed where their installation would compromise the structural integrity of the existing floor system.

2.20.3 Technical requirements. Where provided, hearing loops shall comply with IEC-60118-4 (incorporated by reference in Section 1.3.3).

2.21 Sales and Service Counters and Windows

2.21.1 General. Sales and service counters and windows required to be accessible by applicable building codes and standards shall comply with Section 2.20.

2.21.2 Where required. Where counters or windows are provided for sale or distribution of goods or services, at least one of each type of counter and window provided shall be accessible. Where such counters or windows are dispersed throughout the building or facility, accessible counters or windows shall be similarly dispersed throughout the building or facility.

2.21.3 Technical requirements. Sales and service counter and windows shall comply with Section 904.3 of the ICC A117.1 (incorporated by reference in Section 1.3.2 and reproduced below).

904.3 Sales and service counters and windows. Sales and service counters and windows shall comply with Section 904.3.1 and either Section 904.3.2 or Section 904.3.3. Where counters are provided, the accessible portion of the countertop shall extend the same depth as the public portion of the sales and service countertop provided for standing customers.

Exception: In alterations, when the provision of a counter complying with this section would result in a reduction of the number of existing counters at work stations or a reduction of the number of existing mail boxes, the counter shall be permitted to have a portion which is 24 inches (610 mm) minimum in length complying with Section 904.3.2 provided that the required clear floor space is centered on the accessible length of the counter

904.3.1 Vertical barriers. At service windows or service counters, any vertical barrier between service personnel and customers shall be at a height of 43 inches (1090 mm) maximum above the floor.

Exception: Transparent security glazing shall be permitted above the 43 inches (1090 mm) maximum height.

904.3.2 Parallel approach. A portion of the public use side of the counter surface 36 inches (915 mm) minimum in length and 26 inches (660 mm) minimum to 36 inches (915 mm) maximum in height above the floor shall be provided. A clear floor space positioned for a parallel approach adjacent to the accessible counter shall be provided. The space between the accessible counter surface and any projecting objects above the accessible counter shall be 12 inches (305 mm) minimum.

Exception: Where the counter surface is less than 36 inches (915 mm) in length, the entire counter surface shall be 26 inches (660 mm) minimum to 36 inches (915 mm) maximum in height above the floor.

904.3.3 Forward approach. A portion of the public use side of the counter surface 30 inches (760 mm) minimum in length and 36 inches (915 mm) maximum in height above the floor shall be provided. A clear floor space positioned for a forward approach to the accessible counter shall be provided. Knee and toe clearance complying with Section 306 shall be provided under the accessible counter. The space between the accessible counter surface and any projecting objects above the accessible counter shall be 12 inches (305 mm) minimum.

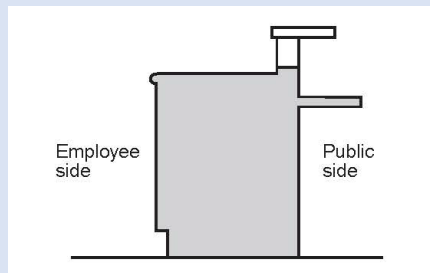

**FIGURE 904.3(A)
SALES AND SERVICE COUNTERS – CROSS SECTION**

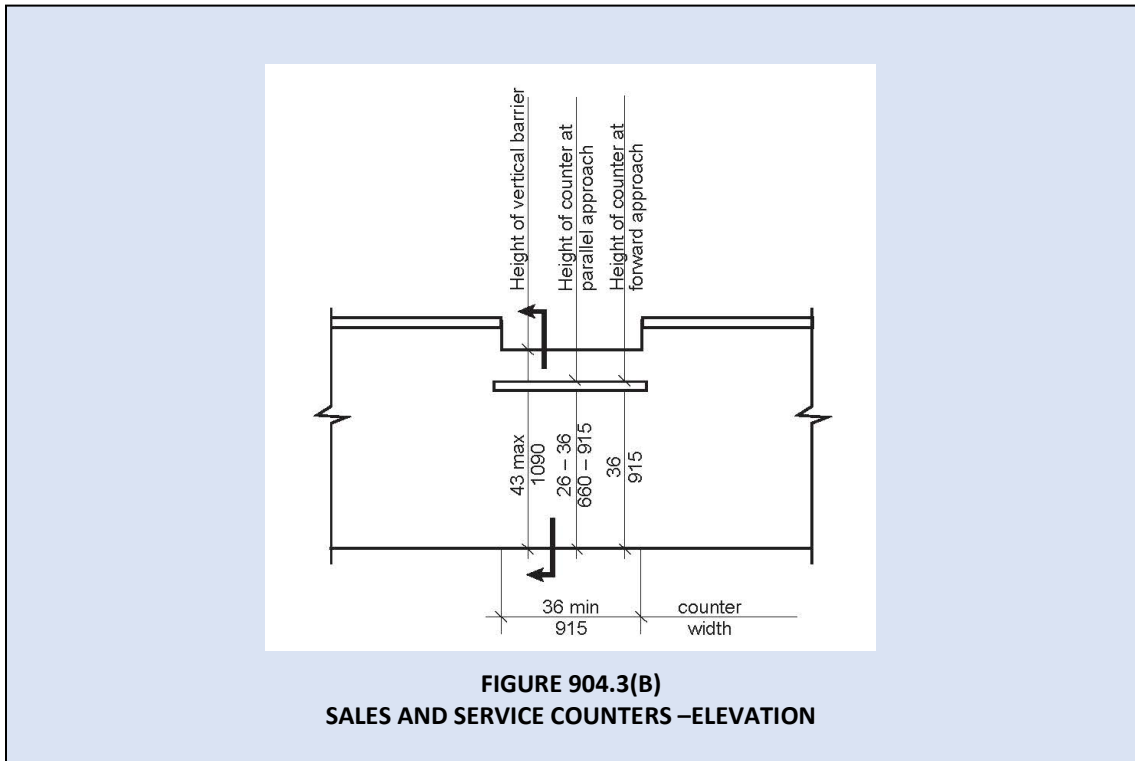

2.22 Accessible Seating at Tables, Counter, and Work Surfaces

2.22.1 General. Seating at tables, counters, and work surfaces shall comply with Section 2.22.

2.22.2 Number required. Where seating or standing spaces are provided at fixed and movable tables, counters or work surfaces in accessible spaces, at least 5 percent of the seating and standing spaces, but not less than one, shall be accessible.

Exception: Where seating or standing spaces are added in an existing space, the requirements of this Section shall apply only to the quantity of seating and standing spaces added.

2.22.3 Dispersion. Accessible seating at tables, counters or work surfaces shall be distributed throughout the space or facility containing such elements and shall be located on a level accessed by an accessible route.

2.22.4 Integration. No more than 75 percent of table seating in any area shall be tables exceeding 34 inches (865 mm) in height above the floor.

2.22.5 Technical Requirements. Seating at tables, counters, and work surfaces shall be accessible in accordance with Section 902 of ICC A117.1 (incorporated by reference in Section 1.3.2).

2.23 Detectable Warnings.

2.23.1 General. Detectable warnings shall comply with Section 2.23.

2.23.2 Where required. Detectable warnings shall be provided in transportation facilities and in the public right-of-way at the following locations:

1. curb ramps and blended transitions at pedestrian street crossings
2. cut-through pedestrian refuge islands that are part of a street crossing;
and
3. transportation platform boarding edges, not protected by platform screens or guards.

2.23.3 Technical requirements. Detectable warnings shall comply with Section 2.23.3, as applicable.

2.23.3.1 Curb ramps. A curb ramp shall have a detectable warning. The detectable warning shall extend the full width of the curb ramp (exclusive of flared sides) and shall extend either the full depth of the curb ramp or 24 inches (610 mm) deep minimum measured from the back of the curb on the ramp surface.

2.23.3.2 Blended transitions. On blended transitions, detectable warning surfaces shall be placed at the back of curb shall be 24 inches (610 mm) deep minimum. Where raised pedestrian street crossings, depressed corners or other level pedestrian street crossings are provided, detectable warning surfaces shall be placed at the flush transition between the street and the sidewalk.

2.23.3.3 Pedestrian refuge islands. At cut-through pedestrian refuge islands, detectable warning surfaces shall be 24 inches (610 mm) minimum in depth and shall extend the full width of the pedestrian route or cut-through. They shall be placed at the edges of the pedestrian island and shall be separated by 24 inches (610 mm) minimum length of surface without detectable warnings.

2.23.3.4 Transportation platform boarding edges. Detectable warning surfaces at transportation platform boarding edges shall extend the full length of the public use areas of the platform. The detectable

warning surface shall extend 24 inches (610 mm) from the boarding edge of the platform.

2.23.3.5 Dome size and spacing. Detectable warnings shall consist of a surface of truncated domes complying with Section 2.23.3.5.

2.23.3.5.1 Dome Size. Truncated domes in a detectable warning surface shall have a base diameter of 0.9-inch (23 mm) minimum and 1.4 inches (36 mm) maximum, a top diameter of 50 percent of the base diameter minimum to 65 percent of the base diameter maximum, and a height of 0.2 inch (5.1 mm).

2.23.3.5.2 Dome Spacing. Truncated domes in a detectable warning surface shall have a center-to-center spacing of 1.6 inches (41 mm) minimum and 2.4 inches (61 mm) maximum, and a base-to-base spacing of 0.65-inch (17 mm) minimum, measured between the most adjacent domes on a square grid.

2.23.3.5.3 Contrast. Detectable warning surfaces shall contrast visually with adjacent walking surfaces either light-on-dark, or dark-on-light.

APPENDIX A – EXPLANATORY MATERIAL

A1.0 Application and Administration

This section clarifies that the requirements contained in *The Port Authority of New York and New Jersey Supplemental Accessibility Requirements* (“supplemental requirements”) are to be applied in addition to any accessibility standards required to be applied during the design, construction, additions to, and alteration of buildings and facilities within its jurisdiction. Although every effort has been made to avoid conflicts with other applicable accessibility requirements, conflicts may exist now or in the future. This section makes clear that when such conflicts occur that the provisions that result in the greatest accessibility must be applied.

Standards referenced in the supplemental requirements are included in this section where they differ from or are not included in other applicable accessibility requirements.

A2.0 Requirements

Sections 2.2 through 2.23 contain both the scoping and technical provisions for the supplemental requirements. In general, these requirements apply when applicable building codes and standards require buildings and facilities to provide accessible elements and spaces. For example, Section 2.3.1 does not require accessible routes to be provided. Instead, when applicable codes and standards require accessible routes, the updated clear width requirements in Section 2.3.2 apply along with any other requirements mandated by the building code or accessibility standard, such as limitations on running and cross slopes.

In some cases, the supplemental requirements convey new obligations not addressed by applicable building codes and standards. For example, Section 2.13 establishes requirements for adult changing stations, not currently required by codes and standards applicable within Port Authority jurisdictions.

A2.1 Applicability (New Construction versus Alterations)

This section establishes that new construction, including additions, must comply with the supplemental requirements. When existing facilities are altered, the altered portions must also comply with these requirements unless “technically infeasible.” “Technically infeasible” is defined and is to be implemented in the same way as in the 2010 Americans with Disabilities Act (ADA) Standards. For alterations, readers should

note that, in addition to the general exception for “technically infeasible” requirements, certain provisions of the supplemental requirements include specific exceptions permitting a lower level of accessibility or, even no accessibility under certain conditions.

Examples:

- A) Section 2.2.3 sets forth requirements for clear floor space for a stationary wheelchair and its occupant. It provides that in new construction, a clear floor space must be 30 inches wide minimum and 52 inches long minimum, and in alterations the length can be reduced to 48 inches minimum.

A lobby is reconfigured and a new ATM is installed where none existed previously. Among other things, the ATM requires a clear floor space for accessibility. Because this is an alteration, the length of the clear floor space must be 48 inches minimum (the ICC A117.1 standard for existing buildings). If even 48 inches is not available, technical infeasibility must be demonstrable. At that point, necessary deviations are permitted.

- B) Section 2.6.2 requires certain public entrances required to be accessible to have a full power-operated door or low-energy power-operated door.

An entrance to a train station is being renovated. As part of the renovation, the doors will be removed and replaced but the existing door frames will be left intact. The designers are questioning whether the renovated entrance will require an automatic door. The answer would be “no” because Section 2.6.2 includes a specific exception for altered entrances unless both the doors and door frames are removed and replaced.

- C) Section 2.15.2 provides that toilet rooms with an aggregate of ten or more male or female water closets must provide a doorless entry and exit or a full powered automatic door.

An existing toilet room with ten or more fixtures in an office building is undergoing alteration. All the fixtures are to be replaced and some will be rearranged to provide better circulation within the room. The entrance to the toilet room is not part of the alteration and currently meets the 2010 ADA Standards. Since the entrance is accessible and is not being altered, the requirement for a doorless entry or automatic door does not apply.

A2.2 Space Requirements

A2.2.1 General. This section adopts and makes enforceable a number of updated dimensions in the 2017 ICC A117.1. The new dimensional requirements apply only to new construction. For existing buildings and facilities, this edition of the ICC A117.1 Standard maintains the dimensions from its previous edition (2009). One of these new requirements increases the length of a clear floor space that accommodates a single stationary wheelchair. This change has rippling effects throughout the document. As a result, several other requirements related to clear floor space were modified in the ICC A117.1 Standard to correlate with the new (longer) dimension. The following discussion focuses only on the new construction requirements.

A2.2.2 Turning spaces. The sizes of circular and T-shaped turning spaces are increased. The minimum diameter of a circular turning space is increased from 60 inches (1525 mm) to 67 inches (1700 mm). There are three new options for T-shaped turning spaces, all of which increase the overall size. For both circular and T-shaped spaces, the permitted maximum depth by which an object can overlap the turning space is reduced from the previous edition.

A2.2.3 Clear floor space. The minimum length of a clear floor space is increased from 48 inches (1220 mm) to 52 inches (1320 mm).

A2.2.4 Clearances at transfer-type showers. The minimum length of the clearance adjacent to a transfer-type shower is increased from 48 inches (1220 mm) to 52 inches (1320 mm). To maintain the alignment of the clearance and the seat for transfer, the length of the clearance is permitted to be measured from the control wall opposite the seat (as in the previous edition) or 4 inches (100 mm) behind the control wall.

A2.2.5 Wheelchair spaces in assembly areas. The minimum depth of a wheelchair space entered from the front or rear is increased from 48 inches (1220 mm) to 52 inches (1320 mm). Although wheelchair spaces generally are not permitted to overlap required aisle widths, a new exception permits the additional 4 inches of wheelchair space depth to overlap the aisle width.

A2.2.6 Companion seat alignment. The requirement to align the shoulder of the occupant of the companion seat with the shoulder of the occupant of the wheelchair space is revised permitting the point of reference for shoulder

alignment to shift within a 4-inch range, reflecting the increase in the depth of the wheelchair space.

A2.3 Accessible Routes

A2.3.1 General. When applicable building codes and standards require an accessible route, this section establishes requirements for the minimum clear width of such routes, and adopts and makes enforceable new provisions in the 2017 ICC A117.1 related to the clear width at turns along accessible routes.

A2.3.2 Clear width. This section does not reference the 2017 ICC A117.1 because it contains one important difference. Like the 2017 ICC A117.1, Section 2.3.2 establishes different clear width requirements for interior versus exterior accessible routes. While interior accessible routes remain 36 inches (915 mm) minimum in clear width, the minimum clear width of exterior accessible routes is increased to 48 inches (1220 mm). However, where the 2017 ICC A117.1 would permit exterior ramps to be only 36 inches (915 mm) in clear width, the supplemental requirements do not include such an exception other than for curb ramps.

This section contains four exceptions. Exceptions 1 and 2 pertain to reduced width segments permitted for accessible routes in new versus existing buildings and facilities, and relates to the increase in the length of a clear floor space. Exception 3 permits routes within outdoor seating areas to remain at 36 inches minimum in clear width. All of these exceptions are consistent with the 2017 ICC A117.1 Standard. We have added a fourth exception permitting the clear width of curb ramps to be 36 inches (915 mm) minimum. As mentioned above, we did not include the fourth exception found in the 2017 ICC A117.1 permitting the clear width of exterior ramps (not curb ramps) to be 36 inches (915 mm) minimum.

A2.3.3 Clear width at turns. This section adopts and makes enforceable Sections 403.5.2 and 403.5.3 of the 2017 ICC A117.1 containing requirements for the clear widths of 180° and 90° turns, respectively.

A2.3.3.1 Clear width at 180° turns. The maximum width of objects obstructing a 180° turn around which an accessible route travels is increased from less than 48 inches (1220 mm) to less than 52 inches (1320 mm). Additionally, there are three options for configuring the turn based on the width of the route approaching, during, and

leaving the turn. The clear width of the route for Options 1 and 2 is the same as those in the previous edition of the Standard. Option 3 requires the route to be 43 inches (1090 mm) wide minimum throughout the turn. Note that Section 2.3.3.1 permits the third option in the 2017 ICC A117.1 to be applied to existing facilities because it offers greater flexibility in design and does not increase the overall space used.

A2.3.3.2 Clear width at 90° turns. At 90° turns, such as those found at the intersection of two corridors, the 36-inch (915 mm) minimum width of accessible routes is increased. There are four options for configuring the turn based on the width of the route approaching, during, and leaving the turn, and whether the corner at the turn is chamfered. An exception allows 90° turns into door and gate maneuvering clearances, elevators, and platform lifts without increasing the 36-inch (915 mm) minimum clear width of the accessible route.

A2.3.4 Passing space. This section adopts and makes enforceable Sections 403.5.4.1 and 403.5.4.2 of the 2017 ICC A117.1 containing provisions for passing space along accessible routes in new and existing buildings and facilities. For new construction, where a T-turn provides required passing space along accessible routes narrower than 60 inches (1525 mm) and exceeding 200 feet (61 m) in length, the length of the base and arms of the “T” must extend 52 inches (1320 mm) minimum beyond the intersection, instead of 48 inches as is allowed for existing buildings.

A2.4 Ramps

A2.4.1 Ramp clear width. The clear width of exterior ramps that are part of accessible routes is increased from 36 inches (915 mm) to 48 inches (1220 mm), consistent with the requirement for clear width on exterior accessible routes. This requirement does not apply to curb ramps.

A2.4.2 Ramp landings. Where a ramp makes a turn between runs, landings must provide clear space 60-inch (1525 mm) minimum by 60-inch (1525 mm) minimum, as opposed to circular or T-shaped turning space.

A2.5 Exception for Operable Parts of Emergency Aid Devices.

Section 2.5 adds a new exception for emergency aid devices used only by emergency personnel in the performance of their duty (Exception 10 to Section 309.1 of the 2017 ICC A117.1). This exception applies to elements that are not provided for building occupants' use such as: fire department hose connections, valve controls, gauges, police call boxes and annunciator panels. The exception does not exempt equipment made available to the public, such as automated external defibrillators (AEDs) and emergency call buttons provided for customers to alert station attendants or others of a need for assistance.

A2.6 Doors, Doorways, and Gate

A2.6.1 General. Consistent with the 2010 ADA Standards, this section adds "gates" to the requirements for doors and doorways, and establishes that doors, doorways and gates required to be accessible by applicable building codes and standards must comply with the supplemental requirements.

A2.6.2 Automatic and Power Assist Doors and Gates

This section requires at least one door at certain entrances that are required to be accessible to have an automatic door. Where the entrance contains two doors in series, such as at a vestibule, both doors must have automatic openers.

Although many people with disabilities can operate an accessible manual door without an automatic door opener, some cannot. Door operation becomes even more difficult when the individual is wearing heavier clothing, such as in the winter, or when the weather is inclement. The intent of this requirement is to afford people with disabilities easier access into buildings. For this reason, the requirements only apply to exterior entrances.

This requirement applies only to certain occupancy groups with minimum specified occupant loads: A-1, A-2, A-3, A-4 with an occupant load of at least 300; and B, M, and R-1 with an occupant load of 500 or more. See the 2018 International Building Code to determine occupancy classifications and occupant loads. In mixed occupancy buildings and facilities, only those entrances that are shared by two or more of the occupancies in the listed groups must comply, and only if the aggregate occupant load equals or exceeds 300.

Examples:

- A)** A new office building (Group B) has an occupant load of 600 and two entrances required to be accessible. Both entrances must have automatic doors because the occupant load exceeds 500, which is the number specified for Group B occupancies in Table 2.6.2.
- B)** A mixed occupancy building contains a boutique hotel (Group R-1) that has an occupant load of 150 and a restaurant (Group A-2) with an occupant load of 75. The hotel and the restaurant are both entered through the hotel entrance. Because the combined occupant load of the hotel and restaurant does not exceed 300, an automatic door is not required.
- C)** A strip mall contains mixed occupancies with an aggregate occupant load over 300. However, because none of the entrances from the exterior are “shared” between two or more of the occupancies listed in Table 2.6.2, automatic doors are not required. However, in this same strip mall, any occupancy listed in Table 2.6.2 that (by itself) has an occupant load sufficient to trigger the requirement must provide automatic doors.

A2.6.3 Technical requirements. Section 2.6.3 adopts and makes enforceable the entire Section 404 *Doors, Doorways, and Gates* of the 2017 ICC A117.1. Changes in this section from current accessibility standards are summarized below:

Gates. To be consistent with the 2010 ADA Standards, the 2017 ICC A117.1 requires “gates” to comply with the requirements for doors.

Maneuvering clearances at manual doors and gates. The minimum length of the maneuvering clearance at forward approaches to manual and sliding doors, gates, and doorways, is increased from 48 inches (1220 mm) to 52 inches (1320 mm). A turning space complying with requirements for new construction or alterations, as applicable, is required between doors in series.

Door and gate hardware. Two new metrics are added for the maximum forces allowed for retracting and discharging latches and other devices that hold the door closed. Previously, the standard did not address these forces. Pushing or pulling motions are limited to 15 pounds (66.7 N) maximum, and rotational motions are limited to 28 inch-pounds (315 N·cm) maximum.

Door and gate opening force. As with the previous edition of the standard, fire doors must have the minimum opening force allowable. This requirement is expanded to apply also to doors or gates “required to be equipped with

panic hardware, break away features or other factors requiring higher opening force for safety reasons.”

Automatic and power-assisted doors and gates. The standard clarifies the distinction between differing types of automatic doors and gates, i.e. full powered, and power-assist and low energy automatic doors and gates. The section also clarifies that only power-assisted doors and gates must provide maneuvering clearances on both sides. Low-energy and full power automatic doors and gates without standby power or that do not remain in the open position when power is withdrawn must provide maneuvering clearances on the egress side only. Full power automatic sliding doors with break out openings need not provide maneuvering clearances.

A2.6.3.1 Marking of transparent doors and fixed adjacent sidelights. This section adopts and makes enforceable requirements for visible markings on transparent doors and fixed adjacent transparent sidelights included in the 2014 Edition of the New York City Building Code. This section applies the requirement to all buildings and facilities subject to the supplemental requirements. This section of the NYCBC includes defined terms and contains detailed specifications for the location, design, and materials to be used as markings.

A2.7 Elevator Car Control Button Identification

This section makes one change to the requirements for raised characters on elevator control buttons. People with low vision frequently report difficulty discerning the visible markings required on elevator buttons, particularly when they have not been activated and are not lit. The 2017 ICC A117.1 requires raised characters and braille floor designations complying with the requirements for signs to be located to the left-hand side of each car control button. On signs, raised characters and braille are not required to contrast with their background if the visual portion of the sign provides adequate contrast.

Unfortunately, people with low vision cannot depend on the markings on elevator control buttons to contrast sufficiently with the buttons under all conditions. Consequently, this section of the supplemental requirements specifically requires raised characters (not the braille) on elevator car control panels to contrast with their background either light-on-dark or dark-on-light.

A2.8 Parking Meters and Pay Stations

Section 2.8 establishes new requirements for parking meters and pay stations. The new requirements are based on the U.S. Access Board's *Proposed Guidelines for Pedestrian Facilities in the Public Right-of-Way* (36 CFR Part 1190) published in the *Federal Register* on July 26, 2011. Although these guidelines are not yet finalized, much of the content has been incorporated in Section 502.10 of the 2017 ICC A117.1 Standard.

When parking meters and pay stations serve parking spaces required to be accessible, the supplemental requirements specify that the operable parts of the equipment must comply with Section 309 *Operable Parts* of the 2017 ICC A117.1 Standard. Additionally, when located adjacent to accessible parallel parking spaces, meters and pay stations must be installed at the head or foot end of the parking space so as not to block car doors from opening fully or prevent side-mounted lifts from being deployed.

Displays and other information on the meter or pay station must be located so as to be visible by a person using a wheelchair (measured 40 inches from the center of the clear floor space that is required at the equipment).

A2.9 Electric Vehicle Charging Stations

A2.9.1 General. This section does not require electric vehicle (EV) charging stations to be provided. However, where such facilities are provided, they must be accessible in accordance with the new supplemental requirements.

A2.9.2 Number of accessible vehicle spaces. Although vehicle spaces at EV charging stations and parking spaces share some similarities, these scoping provisions make clear that parking spaces **not** associated with EV charging stations are to be addressed separately from vehicle spaces provided at EV charging stations. EV charging stations installed in Groups R-2, R-3 and R-4 facilities are exempt from these requirements because they are so often installed in parking spaces assigned to a specific resident of the facility.

At least five percent (5%) of vehicle spaces provided for EV charging on the site, but not fewer than one vehicle space for each type of charging system, must be accessible. However, these provisions do not require an accessible vehicle space at each EV charging station provided on the site. At this time, there are only a few types of EV charging systems provided in public places, depending on the amount of power supplied to the vehicle battery from the grid and the type of connector. Also, the number of accessible vehicle spaces required is based on the total number of vehicle spaces for EV charging provided on the site. These requirements allow flexibility in where the

accessible vehicle spaces are to be located on a site. This is important because accessible EV charging stations must be on an accessible route that connects to accessible elements and spaces on the site, e.g., building entrances and site arrival points. These scoping provisions are based on approved code changes submitted to ICC for the 2021 International Building Code (IBC).

Example:

Three EV charging stations are to be installed in a parking lot serving a large office building. Each station contains ten vehicle spaces. One of these stations will be located on each of three sides of the building. There are two different types of EV charging systems: two provide fast charging (480 V AC) requiring specialized equipment, and the other one provides a slower (208 V) plug and requires less sophisticated connectors.

Based on the total number of vehicle spaces served by the EV charging stations (30), the owner must provide 2 accessible vehicle spaces ($5\% \times 30 = 1.5$ which must be rounded up to 2). Because there are two types of EV charging systems on the site, each of the two accessible spaces must be served by a different type (or both types) of charging system. An accessible route must connect all accessible elements on a site to an accessible building entrance and to site arrival points. Therefore, it is advisable to locate both of the accessible vehicle spaces at an EV charging station on a side of the building containing an accessible entrance and where providing a new accessible route requires the least work.

A2.9.3 Technical requirements. This section (Section 502.11 of the 2017 ICC A117.1 Standard) includes the technical requirements for accessible electric vehicle charging stations.

A2.9.3.1 Vehicle space size. To ensure sufficient maneuvering space around a vehicle parked at the charging station, an accessible vehicle space must be configured as a van space 132 inches (3350 mm) minimum in width with an adjoining access aisle that is 60 inches (1525 mm) minimum in width. A 96-inch wide van space with an adjacent 96-inch wide access aisle is not permitted because this configuration will not allow a driver using a mobility device to circulate around both sides of the vehicle to hook-up the charger, or to avoid cables and other barriers in the route.

- A2.9.3.2 Operable parts.** This section references Section 309 *Operable Parts* of the 2017 ICC A117.1, requiring: clear floor space at operable parts of the charging station, including pay systems and other controls; controls to be within reach ranges specified for persons using wheelchairs; one handed operation without tight grasping, pinching, or turn of the wrist; and, limiting the operating force to 5 lbs.
- A2.9.3.3 Accessible route.** An accessible route must connect the access aisle adjacent to the accessible vehicle space to the clear floor space required at the controls on the charging station. Additionally, when in use, the cable cannot obstruct the required accessible route.
- A2.9.3.4 Obstructions.** This section does not prohibit the use of protective barriers such as bollards and wheel stops. However, it reminds designers that clear floor spaces at operable parts and required accessible routes cannot be obstructed by them.

A2.10 Bus Boarding and Alighting Areas

Where bus boarding and alighting areas are provided in transportation facilities, they must comply with Section 805.2.2 of the 2017 ICC A117.1 Standard. The updated Standard increases the dimension of a newly constructed bus boarding and alighting area (measured perpendicular to the curb) by 4 inches to correlate with the new requirement increasing the length of a clear floor space from 48 inches to 52 inches. This increase will allow wheelchairs with longer wheelbases to clear a bus lift before the user attempts to turn off the lift.

A2.11 Stairs and Ramps

A2.11.1 General. Like other sections, this section relies on applicable building codes and standards to first require stairs and ramps to be accessible before the supplemental technical requirements for stair tread markings, and stair and ramp illumination are applicable. However, unlike other sections of the supplemental requirements, this section defers to the applicable building code or safety standard in the rare event that conflicts exist between the requirements.

A2.11.2 Stair tread markings. When stairs provide a means of egress from public use areas of transportation facilities, this section (Section 504.6 of the 2017 ICC A117.1) requires visually contrasting markings on the leading edges of landings

and stair treads. Additionally, the requirement provides a new range for the width of the contrasting marking from 1 to 2 inches (25 to 51 mm). To avoid conflicts with other code requirements unrelated to accessibility, the standard includes an option allowing compliance with markings required by the applicable building code or another applicable ANSI Standard. Because it is not anticipated that monumental stairs would be part of a required means of egress from a public use area of a transportation facility, an exemption is provided.

A2.11.3 Stair and ramp illumination. This requirement is limited only to stairs and ramps that are part of the path of egress from public use areas in transportation facilities. Initial emergency illumination levels on interior and exterior exit access stairs and ramps leading from public use areas is increased in response to concerns from people with low vision regarding their ability to detect potential hazards in the path under emergency conditions.

A2.12 Bottle Filling Stations

A2.12.1 General. This section does not require bottle filling stations to be provided. However, when provided, they must comply with Section 602.4 of the 2017 ICC A117.1 specifying a clear floor space to be provided at the stations and that hand-operated controls must comply with provisions for operable parts, including being located within accessible reach ranges. This section allows an inaccessible bottle filling station to be located over a high drinking fountain provided that an accessible bottle filling station is also provided at the required wheelchair accessible fountain.

A2.13 Adult Changing Stations

A2.13.1 General. This section requires adult changing stations to be provided and that they comply with the supplemental technical and scoping provisions.

A2.13.2 Where required. Adult changing stations are required at specific areas of airport, bus, rail, or ferry facilities. The new requirement for adult changing stations piggybacks on existing requirements for family or assisted-use toilet or bathing facilities in applicable building codes and standards. Where family or assisted-use toilet or bathing rooms are provided in passenger areas associated with a group of gates, such as a concourse or pier, and in pre-security areas, at

least one of these toilet rooms or bathing rooms in each such area must provide an adult changing station.

Generally, people needing to use these changing stations must not be required to pass through security checkpoints in order to access them. However, in some instances, this is unavoidable because requirements for family or assisted-use toilet rooms are based on the number of toilet fixtures provided in specific areas of covered facilities, and where the number of fixtures provided in a given area does not trigger the requirement for such a toilet or bathing room, one will not be provided. In such instances, Exception 1 to this section allows the route to facilities with adult changing stations to pass through security checkpoints. It does not, however, grant individuals the right to access secured areas if they would not normally be permitted access. Determinations of this type will be made on a case-by-case basis by the entity controlling the checkpoint. For example, in an airport, the Transportation Security Administration controls access.

A second exception to the requirement for adult changing stations acknowledges that an installation in an existing family or assisted-use toilet room could pose insurmountable challenges. Therefore, the requirement is exempted where compliance would require a reduction in the number of required fixtures or an expansion of the area of the room.

A2.13.3 Technical requirements. This section contains new technical provisions for adult changing stations based on similar requirements in Section 11B-813 of the 2019 California Standards for Accessible Design Guide. Adult changing stations are available for purchase; specifiers must ensure that selected fixtures meet these requirements.

A2.13.3.1 Changing surface. This section requires a changing surface 28 inches minimum in width and 70 inches minimum in length comprised of materials that are hard, non-porous, non-absorbent, durable, and resistant to damage and discoloration by certain disinfectant cleaning products.

A2.13.3.2 Clearances. To accommodate a caregiver and provide unobstructed access to the person being changed, the changing surface must be surrounded on three sides (including the head and foot) by a 36-inch wide clearance that is nominally planar and does not have abrupt changes in level. To accommodate a caregiver and provide unobstructed access to the person being changed, the

changing surface must be surrounded on three sides (including the head and foot) by a 36-inch wide clearance that is nominally planar and does not have abrupt changes in level.

A2.13.3.3 Height adjustability. Continuous height adjustability (from 17 inches to 38 inches) facilitates transfers between mobility devices and the changing surface and allows caregivers to raise the surface to a height where they can best perform their duties. Controls for height adjustment must be accessible in accordance with Section 309 of the 2017 ICC A117.1.

A2.13.3.4 Capacity. The changing station must be capable of supporting 300 pounds (136 kg) and allowable stresses cannot be exceeded for the materials used.

A2.13.3.5 Stability. To protect all users, the changing station must be secured to the floor, wall, or both.

A2.13.3.6 Accessible routes. When not in use, changing stations must not obstruct accessible routes within the toilet or bathing room. When this requirement is applied to changing stations that fold-up or stow away, it means that the station cannot overhang or otherwise block a required accessible route when in the stowed position. Consequently, to ensure access to the toilet or bathing room by subsequent users, it is expected that changing station users will return the equipment to a closed position after use.

A2.14 Water Closets and Toilet Compartments

A2.14.1 General. When accessible water closets and toilet compartments are required by applicable building codes and standards, they must comply with the supplemental requirements.

A2.14.2 Toilet compartments: minimum number and type. Like the 2018 IBC, this section requires five percent of the toilet compartments in a toilet room to be wheelchair accessible compartments. When two or more wheelchair accessible compartments are required in a toilet room, at least one must be the typical wheelchair accessible compartment complying with Section 604.9.2.1 of the 2017 ICC A117.1 (consistent with the 2010 ADA Standards). Of the remaining compartments required to be accessible, at least one must be

an “alternate wheelchair accessible compartment” complying with new requirements in Section 604.9.2.3 of the 2017 ICC A117.1. (See *Water closet compartment size* under 2.14.3 *Technical requirements* for a description of this new technical requirement.)

A2.14.3 Technical requirements. This section adopts and makes enforceable Sections 604 of the 2017 ICC A117.1 containing requirements for water closets and toilet compartments. The section includes a number of important changes from previous editions summarized below:

Rear wall grab bar (Section 604.5.1). To provide a more consistent measuring point, the location of the rear wall grab bar is no longer measured from the center line of the water closet. Instead, it is to be installed 6 inches maximum from the side wall and extend 42 inches minimum from the side wall.

Dispenser and dispenser location (Section 604.7). The 2009 edition of the ICC A117.1 revised the dispenser location to be measured from the rear wall instead of from the front of the water closet as is required by the 2010 ADA Standards. The 2017 Edition added an exception to allow an option to measure the dispenser location from the water closet.

Water closet compartment size (Section 609.2.3). A new compartment option is added allowing a door installed in the front partition to swing into the toilet compartment provided that the minimum depth of the compartment is 84 inches. This configuration will allow those who prefer to do so, to approach the water closet from the front.

Compartment door maneuvering clearance (Section 604.9.3 and 604.10.3). These sections establish that door maneuvering clearances are not required within wheelchair accessible compartments. Another clarification indicates that the 42-inch wide accessible route is required only when approach to the compartment is from the latch side.

A2.15 Toilet Rooms

A2.15.1 General. This section contains two new provisions applicable to accessible toilet rooms: one for doorless entries and exits into and from certain large toilet rooms, and another to ensure privacy in single-family toilet or bathing rooms.

A2.15.2 Entries and exits. Doorless entries and exits or full powered automatic doors must be provided for toilet rooms that contain an aggregate of ten or more male or female water closets. Male and female toilet rooms can be accessed by the same entry and exit, such as is common in airports and other similar facilities. Note that plumbing codes typically count two urinals as one water closet. See also Example C under Section 2.1 *Applicability to New Construction versus Alterations*.

A2.15.3 Privacy in family or assisted use toilet rooms. Consistent with approved changes to the 2018 IBC for the 2021 Edition, this section requires an “occupied” indicator” in addition to the existing requirement that doors be securable from within a family or assisted-use toilet room. This indicator will make it easier for users waiting to use the room to respect the privacy of persons already using the room.

A2.16 Showers: Grab Bars and Hand Shower

A2.16.1 General. Where showers are required to be accessible by applicable building codes and standards, the supplemental requirements add new provisions for grab bars and hand showers.

A2.16.2 Grab bars in roll-in type showers. This section adopts and makes enforceable Sections 608.3.2 through 608.3.3 of the 2017 ICC A117.1. The Standard adds a new requirement for a vertical grab bar in a standard roll-in shower. This grab bar is provided to assist individuals who do not use shower chairs to enter the compartment and raise and lower themselves from the seat. Consequently, when the side wall opposite the seat that would support the grab bar is more 72 inches from the seat wall, the grab bar is not required. Other minor changes to the format of the section improve the flow and clarify previous ambiguities.

A2.16.3 Hand showers (alternate roll-in showers). This section adopts and makes enforceable Section 608.4.3 of the 2017 ICC A117.1 governing the location of hand showers in alternate roll-in showers. The location of the controls and hand shower in alternate roll-in showers is restricted so that they do not overhang the seat and are within reach of a person using the seat. When located on the end wall adjacent to the seat, they must be 16 inches (405 mm) minimum and 27 inches (685 mm) maximum away from the seat wall and; and when located on the back wall opposite the seat, they must be within 15

inches (380 mm) of the centerline of the seat toward the transfer space (open side).

A2.17 Sauna and Steam Room Doors

A2.17.1 General. An existing provision in the ICC A117.1 requires saunas and steam rooms to provide a clear floor space positioned at the end of the bench seat and parallel to its short axis so that a person can transfer laterally from a wheelchair onto the seat. Generally, doors are not permitted to swing into this clear floor space. However, a current exception in the 2010 ADA Standards permits the door to swing into the clear floor space provided that the room is for individual use and there is a clear floor space beyond the arc of the door where a person using a mobility device can pull-up beyond the door swing and then reposition for transfer onto the seat. This exception is incorporated in the 2017 ICC A117.1 and is reproduced in this section of the supplemental requirements.

A2.18 Kitchen Sinks

A2.18.1 General. For non-commercial employee kitchens (employee break rooms and kitchenettes) this section overrides an exception in the 2009 and 2017 editions of the ICC A117.1 and the 2010 ADA Standards permitting a side approach to a kitchen sink where a cooktop or conventional range is not provided within the kitchen. While a side approach is sometimes permitted at various elements, this requirement will benefit employees who do not have the use of both hands or both sides of their bodies and those using the sink for something more than the simplest tasks, such as filling a coffee pot.

A2.19 Signs.

A2.19.1 General. This section applies to signs required to be accessible by applicable building codes and standards, including the 2010 ADA Standards. Readers should be aware that most building codes do not address the broad range of signs required to be accessible by the ADA, such as room identification signs and informational signs. Section 2.19.1 contains provisions for a non-glare finish based on new requirements in Sections 703.2.10.1 (visual characters), 703.5.3.1 (pictograms), 703.6.2.1 (symbols of accessibility) of the 2017 ICC A117.1.

A2.19.2 Non-glare finish. This section provides a metric for limiting the amount of glare on signs from coverings and finishes and does not allow it to exceed 19 gloss units (gu) as measured on a 60-degree gloss meter.

A2.19.3 Toilet room signs. A new provision is added to require specific pictograms on toilet room signs. This will assist people with cognitive disabilities or low vision to navigate to and locate toilet rooms. Consistent signage for these critical facilities is helpful, particularly because people with certain types of disabilities find it difficult to decipher unfamiliar graphics and others cannot read the text equivalents required for pictograms. To ensure this needed consistency and the legibility of the graphics used, the requirements reference pictograms that are included in standards issued by the International Standards Organization (ISO): one for toilet rooms that are not gender-specific; one for toilet rooms for men's use; and another for toilet rooms for women's use. It is permissible to combine these pictograms with the International Symbol of Accessibility, which is required to identify toilet rooms when not all are accessible.

A2.19.4 Hearing loop symbol. This section specifies a particular sign to be displayed where hearing loops are provided. The "T" on the sign is understood to mean "telecoil" or "T-coil" which is activated by a switch on hearing aids or on the external part of a cochlear implant. The T-coil allows the device to connect wirelessly to the audio provided by the hearing loop. The letters "CI" on the sign mean "cochlear implant."

A2.20 Hearing Loops (Induction Loop-type Assistive Listening)

A2.20.1 General. For some time, accessibility standards have required assistive listening systems in certain assembly spaces, such as theaters, stadia, courtrooms, classrooms, and lecture halls. This section establishes a new requirement for a particular type of assistive listening system (hearing loop, also known as an induction loop) to be provided in spaces in transportation facilities not previously covered by the requirements.

A2.20.2 Where required. These supplemental requirements specify that hearing loops are to be installed in airports, bus, rail, and ferry facilities at the locations specified in Sections 220.2.1 and 2.20.2.2. Although current accessibility standards require facility owners and operators to maintain and distribute receivers to be used with assistive listening systems, these supplemental requirements for hearing loops contain an exception for receivers where hearing loops are installed in accordance with this section or are voluntarily provided at similar locations. Unlike a theater, the locations where hearing loops will be required do not present an efficient way to distribute and reclaim receivers. For this reason, it is expected that the primary beneficiaries of this requirement will be people who wear programable hearing aids or have

cochlear implants that can connect directly to the signal without using a receiver.

A2.20.2.1 Information counters. Staffed traveler information counters in airport, bus, rail, and ferry facilities must provide hearing loops. Such counters do not include sales counters where tickets are sold or service counters such as baggage drop-off or rental car counters. They would include counters where staff provide travelers general information such as directions to terminals, tourist information, or schedules for public transportation serving the area.

A2.20.2.2 Passenger gates. Each passenger gate in airport passenger terminals must provide a hearing loop that is designed to transmit all audible announcements broadcast to the gate such as gate changes, boarding announcements, passenger pages, and emergency announcements.

Because not every alteration to a passenger gate presents the opportunity to install a hearing loop, we have included an exception for hearing loops when their installation would require compromising the structural integrity of an existing floor system. This exception is intended to apply only where a hearing loop cannot be effective unless it is installed in the floor and where the structure of the floor would not otherwise be compromised by the alteration.

A2.20.3 Technical requirements. This section references and makes enforceable a set of system performance requirements for induction loops (hearing loops) intended to be used with hearing aids – IEC-60118-4. The full abstract of the standard can be found at <https://webstore.iec.ch/publication/798>.

A2.21 Sales and Service Counters and Windows

A2.21.1 General. This section adds scoping for accessible service windows to the current requirements for accessible sales and service counters.

A2.21.2 Where required. Because sales and service “windows” were not clearly addressed in earlier accessibility codes and standards, the requirements add new provisions for them that are based on approved changes to the 2018 IBC

that will be included in the 2021 IBC. This section adds sales and service “windows” to the list of places where accessible sales and service “counters” are required. It also requires these accessible sales and service windows to be dispersed within a facility in the same manner as accessible sales and service counters. The major distinction between sales and service windows and counters is that windows typically do not provide a countertop for customer use.

A2.21.3 Technical requirements. This section adopts and makes enforceable Section 904.3 of the 2017 ICC A117.1 which now includes provisions for sales and service windows. The new requirements also address vertical barriers at both sales or service windows and counters. When a vertical barrier exists between personnel and customers, regardless of whether or not it is provided for security, the vertical barrier cannot extend more than 43 inches above the floor (approximate eye level of a person using a wheelchair) unless it is transparent glazing. This allows a person using wheelchair and personnel behind the window or counter to be visible to one another and provides for more effective communication.

A2.22 Accessible Seating at Tables, Counter, and Work Surfaces

A2.22.1 General. This section establishes a requirement for seating at tables, counters, and work surfaces to comply with the technical and scoping requirements below.

A2.22.2 Number required. This section significantly revises the basis for calculating the number of required accessible seats. The current practice only counts the number of seats provided at fixed or built-in tables, counters, and work surfaces. This could result in an inequitable application of the requirements for accessible seating, particularly when the majority of seating is movable furniture, such as in a restaurant providing fine dining. The supplemental requirements will apply to all seating and standing spaces at tables, counters, and work surfaces regardless of whether it is fixed or built-in or not.

This section primarily affects restaurants, bars, and other similar facilities that provide tables and counters for the consumption of food and drink. Work surfaces used only by employees are not required by accessibility codes and standards to be accessible. However, this requirement will apply to a work surface provided for customer use, such as in a post office lobby regardless of whether the work surface is fixed or built-in.

A2.22.3 Dispersion. The dispersion requirement is unchanged from current accessibility codes and standards.

A2.22.4 Integration. This section addresses the proliferation of high-top tables in many bars and restaurants. It requires that no more than 75% of table seating in any area be higher than 34 inches. Although only 5% (not 25%) of the table seating in any given area is required to be accessible, when 25% of the seating in the area is comprised of lower tables, people with disabilities seated at accessible tables are better integrated in the seating area. Full and meaningful integration is a key component of all accessibility requirements. This new requirement should allow people with disabilities to fully enjoy the social benefits of dining in public places without being isolated or segregated by the presence of high tables.

A2.22.5 Technical Requirements. The technical requirements for accessible seating in Section 902 of 2017 ICC A117.1 is incorporated by reference for the ease of the reader. It does not contain significant changes from the previous edition of the Standard.

A2.23 Detectable Warnings

A2.23.1 General. This section establishes that detectable warnings must be provided at the locations specified in Section 2.23.2 and comply with the technical requirements in Section 2.23.3.

A2.23.2 Where required. The locations where detectable warnings are required in this section are consistent with scoping requirements in the U.S. Department of Transportation's requirements and policies implementing the ADA, as well as the Federal Transit Administration's requirements for entities receiving federal financial assistance. This section clarifies that detectable warnings are to be provided at street crossings within transportation facilities and in the public right-of-way.

A2.23.3 Technical requirements. The requirements in Sections 2.23.3.1 through 2.23.3.4 of the supplemental requirements are consistent with current DOT ADA requirements for the locations specified. Some of the terms used in these sections, such as "blended transition" and "pedestrian refuge island" derive from the U.S. Access Board's *Proposed Guidelines for Pedestrian Facilities in the Public Right-of-Way* published in the Federal Register on July 26, 2011. The requirements for dome size and spacing in this section are reproduced from Section 705 of the DOT ADA Standards.

APPENDIX B – ADDITIONAL CONSIDERATIONS FOR ACCESSIBILITY

Introduction

This document outlines nine accessibility topics that were not included in the Supplemental Accessibility Requirements but that nevertheless merit careful consideration. While not mandatory in every project, we ask architects and design professionals to consider these issues if applicable to their project and, to the best of their ability, to address them.

B1. Avoid Accessible Routes Behind Parking Spaces

Locate accessible parking on the building side of the drive aisle in surface lots, or contiguous to accessible lobbies in parking structures.

Background. A wheelchair user who drives a car and parks in an accessible parking space close to the building entrance may have to wheel behind a car parked in another accessible space to get to the entrance. Based on a number of factors, including the stature and seated height of a wheelchair user, the top of their head may be below the sightline of a driver backing out of a space. In response to this concern, many people with disabilities advocate not allowing the accessible route for a parking space to travel behind parked cars. Such a prohibition could result in forcing the accessible route out of the drive aisle and requiring it to be located at the front of parking spaces. Such a solution could have an overall impact on the space available for parking. Another, and simpler, solution is to locate accessible parking on the building-side of the drive aisle.

B2. Provide Pedestrian-Only Walks Through Surface Parking Lots

Protect blind or low vision travelers with pedestrian-only walks through surface parking lots (not applicable in parking structures).

Background. Independent travelers who are blind or have low vision who arrive at a facility by public transportation or on foot will need to navigate from the public sidewalk or right-of-way to a building entrance. When buildings and facilities are surrounded by parking lots, this can be a difficult task, even when the traveler knows the route. Organizations of people who are blind or have low vision advocate for “pedestrian only” walks through parking lots where they can travel with greater confidence. Although such walks necessarily will be interrupted by streets or drive aisles, a walking route separated

from traffic can significantly reduce pedestrian and vehicle interaction and make navigating a parking lot without vision far safer.

B3. Co-locate accessible and inaccessible routes

Locate Elevators Near Stairs and Escalators.

Background. Accessibility standards typically require at least one accessible route to connect accessible spaces and elements within a building. Additionally, accessible routes must coincide with, or be located in the same area, as general circulation paths used by building occupants without disabilities. These requirements generally result in pairing elevators and ramps with stairs and escalators so that the building's wayfinding system works equally well for everyone. However, as buildings become larger and more complex with multiple routes and destinations, people with disabilities cannot always depend on the collocation of accessible and inaccessible vertical routes, and traditional wayfinding systems (signage and other cues) often fail to serve these users. For example, when a person using escalators can travel from one floor to the next using stacked escalators, a person requiring an accessible route also should be able to use a nearby elevator to travel from floor-to-floor. However, when elevators don't serve the same floors served by the escalators, the route is less intuitive and may impose significantly greater travel distances on people with disabilities.

Consider installing overhead signs at decision points along circulation paths to indicate the location of accessible routes and the destinations they serve. When signs are discretely placed on walls or pillars, a person using a wheelchair – whose eye level is below the shoulders of standing persons – can easily miss these signs because they are blocked from view by other people.

B4. Provide Digital Wayfinding

Offer digital wayfinding kiosks or smartphone apps.

Background. Advanced digital wayfinding systems are now available and can assist people with a variety of disabilities to plan a trip and to navigate a facility in real-time. Such systems include interactive maps, directories, and directions that can be delivered through a kiosk or an app on a cell phone. When considering a digital wayfinding system, make sure that it can be programmed to include accessibility information, and that associated kiosks, websites, and apps are accessible to users with disabilities. For information on how to make digital systems accessible, Section 508 of the Rehabilitation Act of 1973 establishes [standards](#) for accessible information and communications

technology purchased or developed by federal government agencies. Although currently applicable only to the federal government, these standards can help designers to ensure that digital wayfinding systems are accessible to everyone.

B5. Provide Resting Intervals and Handrails on Long Routes

Design an additional level resting area with handrails and seating every 200-500 feet of travel at long accessible routes, in addition to those required for ramps.

Background. Although it is counter-intuitive to require people with mobility disabilities to travel further than people without disabilities, longer distances are sometimes a consequence of accessible design. For example, a walk sloped at 1:20 is longer than a ramp at 1:12 or stair connecting the same levels. Because many people with disabilities have limited stamina, giving them a place to rest can make independent travel more feasible. Ramps must have level landings for every 30 feet of rise; walks no steeper than 1:20, however, are not required to have places to rest. Consider installing a flat resting area on or adjacent to lengthy routes (every 200-500 feet), even if doing so means that a portion of the overall route must be slightly steeper or even a ramp. Level areas that allow a manual wheelchair user to safely rest without risking tipping or rolling backwards can save wear and tear on shoulders and wrists.

People who do not use wheelchairs but nonetheless require an accessible route, appreciate a place to sit and rest when traversing long routes. The 2010 ADA Standards and other accessibility standards do not require indoor and outdoor seating provided for resting to be designed for transfer from a wheelchair – such standards apply only to benches provided for bathing and dressing. However, if such seats have back rests and at least one arm, people with limited mobility, such as those using crutches or other walking aids, will find it easier to rise from the seat. Also, seating should be designed at a height that allows a person to keep their feet in contact with the ground for better balance, and to preserve blood flow to the lower limbs.

Handrails along routes can provide stability and a place to rest, particularly where seating is not feasible. Accessible routes that are “walks” are not considered “ramps” because they are sloped 1:20 or less. As such, they are not required to provide handrails under accessibility codes and standards such as the ICC A117.1 and the 2010 ADA Standards. However, as noted above, longer shallower routes can be more stressful for some people with disabilities than ramps, or even stairs. Providing occasional handrails or other support surfaces, even though they are not required under the ADA, can assist users who have difficulty walking or who use manual wheelchairs to travel longer distances.

Similarly, handrails are not required in elevators, but they can be helpful to people using elevators if they have difficulty maintaining their balance when the elevator is in motion or comes to an abrupt stop.

B6. Provide Paratransit Pick-up Areas

Design sheltered (indoor when possible) seating at paratransit pickup locations.

Background. Many people with disabilities depend on a form of public transportation known as “paratransit.” Paratransit is door-to-door transportation, typically using small buses, vans, or taxis and requiring advance reservations. While some facilities designate a passenger loading zone for paratransit pick-up and drop-off, more often than not, passengers must wait in undesignated spaces inside or outside entrances to the facilities they visit. Paratransit services are often delayed and can include extended waiting times; missed paratransit pick-ups frequently cannot be rescheduled. For these reasons, we recommend providing seating to accommodate riders as they await pick-up. Such seating should be sheltered from the weather – ideally inside a lobby, and the seating location should allow riders a view of the pick-up area whether it is a formal passenger loading zone, or simply at the curb near the building entrance. Such seating does not need to be designated for specific use or feature signage.

B7. Provide Visual Contrast

Provide visual contrast at elements, including at abrupt changes in level, doors and walls, doors and floors, controls against restroom fixtures and handrails against walls.

Background. To address the needs of people with vision loss, accessibility standards include criteria requiring the visual portions of signs to provide contrast between the characters and their background (light-on-dark or dark-on-light).

While requiring contrast on signs, none of the accessibility standards used in the United States include an enforceable metric for determining whether a sign complies with the light-on-dark or vice versa contrast criteria. No proposed methods have received wide acceptance – possibly due to concerns that, if these criteria were made mandatory, building owners would be challenged to maintain contrast levels over time as signs and other surfaces become worn.

Visual contrast is not only important on signs. Accessibility standards also require detectable warnings at street crossings and on transit platform edges to contrast (light-

on-dark or dark-on-light). The Supplemental Accessibility Requirements also mandate contrast at the edges of stair treads and landings on egress routes.

Other areas where visual contrast is not required but could be helpful include: abrupt changes in level, doors and walls; walls and floors; controls against restroom fixtures; and handrails against walls. Very few people with vision impairments are totally blind – about 5%. Even those with very little residual vision may depend on a perception of visual contrast which allows them to anticipate an obstacle or to locate an objective.

While there may be no widely accepted metric for accessible contrast, designers and builders should be aware of the need for visual contrast at certain elements and should provide visual contrast when possible.

B8. Install Hearing Loops at Ticketing or Customer Service Counters

Provide hearing loops at counters in transportation facilities (not only at passenger gates and information counters).

Background. To facilitate communication with those who use hearing aids or cochlear implants, the Supplemental Accessibility Requirements mandate a particular type of assistive listening system, known as a hearing loop or audio induction loop at a few locations in transportation facilities (i.e., airline passenger gates and certain passenger information counters in airline, bus, rail, and ferry facilities). Unlike the assistive listening systems required by the ADA and the IBC in places like theaters, classrooms, courthouses, and similar facilities, the loop systems required in transportation facilities will not be required to provide receivers and headsets so that listeners can hear public address announcements or take part in a conversation over the counter.

Loop systems generate a magnetic wireless field that transmits the audio signal directly into a hearing aid or cochlear implant through a telecoil. Listeners can connect to the signal and control the volume using the telecoil or “T”-switch on their hearing aids or implants. Like other types of assistive listening systems, loops bring the sound directly to the ear of the listener reducing reverberation and bypassing background noises and the sounds emanating from the space between the speaker and the listener. According to the International Hearing Loop Manufacturer’s Association, speech comprehension can be increased from 0-10% to as much as 90%. This technology enables more effective communication and reduces the need for other types of accommodations such as passing notes, or assigning staff to individually notify passengers with hearing loss that their planes are delayed.

Although the Port Authority does not require hearing loops at all transaction counters, we strongly recommend considering where they could be useful. For example, often the conversation at airline ticketing counters involves a lengthy discussion of travel options, costs, and other considerations. If some or all of the counters have hearing loops, everyone (staff and travelers) can benefit from a more comfortable and less frustrating information exchange. Other places where personal information must be exchanged, such as car rental desks, currency exchanges, and teller stations could also benefit from this treatment.

B9. Provide Accessible Classroom Acoustics

Utilize the 2017 ICC A117.1 enhanced classroom acoustics provision or the ANSI ASA S12.60 Standard.

Background. The 2017 ICC A117.1 contains provisions for enhanced acoustics in classrooms (Section 808) and the 2021 International Building Code (IBC) will require these criteria to be applied in primary and secondary schools. These provisions are based on some of the criteria in a voluntary standard developed by the Acoustical Society of America, the ANSI/ASA S12.60-2010/Part 1 (R2015) *Acoustical Performance Criteria, Design Requirements, and Guidelines for Schools, Part 1: Permanent Schools*. The 2017 ICC A117.1 Standard limits reverberation time in classrooms 20,000-cubic feet or less. Compliance can be demonstrated using a performance method (on-site testing) or a prescriptive method (calculations based on materials and methods). The requirements also address sources of ambient noise from within and outside the classroom, measured when the space is unoccupied.

A good acoustical environment is critical for people with hearing loss, certain learning disabilities, and those acquiring a second language. Assistive listening systems and other types of amplification only facilitate communication between the person using the microphone, usually the teacher, and a listener with hearing aids or a cochlear implant equipped with a telecoil or a person using a special receiver and headphones. Communications among students are equally important to learning. The Port Authority wants its training rooms and other instructional spaces to perform well acoustically so that occupants have the opportunity to learn under conditions that do not exacerbate a hearing impairment or other disability. Consequently, we strongly encourage designers to be mindful of the acoustical environment in training rooms, meeting rooms, and any other spaces where classroom-style instruction may take place. Consider reviewing and applying the 2017 ICC A117.1 enhanced classroom acoustics requirement or the ANSI ASA S12.60 Standard to the extent practicable.

APPENDIX C – TOPIC BY TOPIC SUMMARY

The tables below provide a convenient summary of the provisions in the Supplemental Accessibility Requirements. The tables are organized by topic, so the provisions are not necessarily in the order they appear in the Requirements. Please note that the summaries are not intended to be comprehensive. For the full details of any provision, please refer to the Supplemental Accessibility Requirements.

Application and Administration

Provision	Topic	Summary
1.1	Purpose	These are new supplemental scoping and technical provisions for accessibility in Port Authority projects.
1.2	Conflicts with Other Accessibility Standards	If there are conflicts, apply standard that results in greater accessibility.
1.4	Referenced Standards	List of referenced standards, with links.
2.1	Applicability	These requirements apply to new construction. They also apply to alterations unless there is an exception or if technically infeasible.

Accessible Space “Building Blocks”

Provision	Topic	Summary
2.2.2	Turning Spaces	Wheelchair turning space increased from 60” to 67” (or larger T-shape)
2.2.3	Clear Floor Space	Wheelchair clear floor space increased from 30” x 48” to 30” x 52”.

Parking

Provision	Topic	Summary
2.8	Parking Meters and Pay Stations	Parking meters and pay stations that serve accessible parking spaces must have accessible operable parts with displays visible from a wheelchair.
2.9	Electric Vehicle Charging Stations	Accessible vehicle space (van sized) required at electric vehicle charging stations (5%). Unobstructed accessible route required from accessible vehicle space to charging station and accessible operable parts are required at stations. Parking in other areas is treated separately.

Doors

Provision	Topic	Summary
2.6.2	Automatic and Power-assist Doors and Gates	At least one automatic door is required at each entrance to high occupancy buildings. Not required in alterations unless door and door frame are replaced.
2.6.3	Doors, doorways, and gates	<ul style="list-style-type: none"> • Maneuvering space at forward approach doors increased from 48" to 52". • Requires doors with panic hardware and similar features to meet the minimum opening force allowable (not subject to maximum, as with fire doors). • Clarifies automatic door types and maneuvering clearance requirements at automatic doors. • Force maximums are applied to door hardware operation except panic hardware, delayed egress devices, and fire-rated hardware.
2.6.3.1	Doorway Markings	Visible markings required on transparent doors and sidelights.

Accessible Routes

Provision	Topic	Summary
2.11.2	Stair treads	Visual contrast required at edges of first 1-2 inches of stair treads and landings on egress routes.
2.11.3	Emergency illumination levels	Initial emergency illumination levels for egress ramps and stairs increased to 2 footcandles min. in transportation facilities.
2.3.2	Clear width (accessible routes and ramps)	Exterior accessible route and ramp width increased from 36" to 48".
2.3.3, 2.3.4	Clear width (at turns and passing spaces)	Increased clear width requirements at 90° and 180° turns on accessible routes; Size of passing space along accessible routes increased.
2.4.2	Change in direction (Ramp landings)	60" x 60" landing required where ramps make a turn between runs.
2.23	Detectable Warnings	Clarifies that detectable warnings are required at street crossings in transportation facilities and in the public right-of-way.

Restrooms

Provision	Topic	Summary
2.15	Toilet Rooms	<ul style="list-style-type: none"> Doorless entry or automatic doors required at restrooms with 10 or more water closets. Family and assisted-use restrooms shall have an "occupied" indicator.
2.14	Alternate Accessible Toilet Stalls	Five percent of toilet compartments must be wheelchair accessible. In a large restroom, at least one must be an alternate type elongated compartment with a door in the front partition that can swing in.
2.13	Adult Changing Stations	<p>Adult changing stations are required in at least one family restroom in every transportation facility, and on each side of security in each airport terminal. Adult changing stations must have:</p> <ul style="list-style-type: none"> 28 x 72" changing surface min. Clear space at head, foot and one side.

		<ul style="list-style-type: none"> • Be height adjustable 17” -38” • 300 lbs. min. weight capacity • Stable and not obstruct accessible routes.
2.14.3	Toilet Rear Grab Bars	Rear toilet grab bar measured from wall, not toilet center.
2.14.3	Toilet Paper Dispensers	Toilet paper dispenser location can be measured from rear wall.
2.14.3	Toilet Stall Doors	Doorway maneuvering clearances are not required from inside toilet compartments; 42” wide route for side approach to compartment door only required when approaching latch side.
2.19.2	Restroom Signs	Specific pictograms required on restroom signs (male, female, not gender specific).

Retail

Provision	Topic	Summary
2.22	Accessible Seating at Tables, Counters, and Work Surfaces	Accessible seating rules also apply to non-fixed tables and counters; no more than 75% of seating can be more than 34” high in any area.
2.21	Sales and Service Counters and Windows	Clarifies that service windows are subject to accessibility requirements, along with counters. <ul style="list-style-type: none"> • 36” maximum height for accessible counters and windows. • Non-transparent vertical barrier at service windows or counters cannot be higher than 43 inches.

Showers and Saunas

Provision	Topic	Summary
2.2.4	Transfer-type shower clearance	Clearance adjacent to accessible transfer shower increased from 48” to 52” in length for new construction.
2.16	Shower Grab Bars	Accessible shower grab bar dimensions are provided, and a vertical grab bar is required.
2.16	Shower Control Location	Controls in alternate accessible showers must be within reach of seat.

2.17	Sauna Bench Location	Sauna doors can swing into clear floor space at bench if another clear floor space is provided beyond the swing of the door.
------	----------------------	--

Miscellaneous

Provision	Topic	Summary
2.10	Bus Boarding and Alighting Areas	Accessible bus boarding area increased from 96" to 100" for new construction.
2.20, 2.19.3	Assistive Listening Systems, Hearing Loops	<ul style="list-style-type: none"> • Hearing Loops (induction loops) required at passenger gates in airports and staffed information counters at all transportation facilities. Not required in alterations if installation would compromise the structural integrity of the floor. • Hearing loops must comply with IEC-60118-4 • Specific signage required for spaces served by hearing loops.
2.12	Bottle Filling Stations	Requires accessibility at bottle filling stations.
2.2.5, 2.2.6	Wheelchair spaces in assembly areas	Wheelchair space in assembly areas increased from 48" to 52" and 4" can overlap the aisle in new construction. Shoulder alignment of companion seats in row seating adjusted to accommodate increased length of wheelchair space.
2.5.1	Operable Parts	Accessibility of operable parts not required for emergency aid devices operated only by emergency personnel.
2.7	Elevators	Raised characters on elevator control panels must contrast visually with their background.
2.18	Employee Kitchen Sinks	Open space required under employee break room sinks for forward approach, even if no cooktop or range provided.
2.19.1	Glare on Signs	Maximum glare established for signage (19 gu).